

Projections of Planes

- Girish Hanumaiah

Projections of Planes

1. (1) An equilateral triangular lamina of 25 mm sides lies with one of its edges on HP such that the surface of the lamina is inclined to HP at 60 deg. The edge on which it rests is inclined to VP at 60 deg. Draw its projections.

Solution:

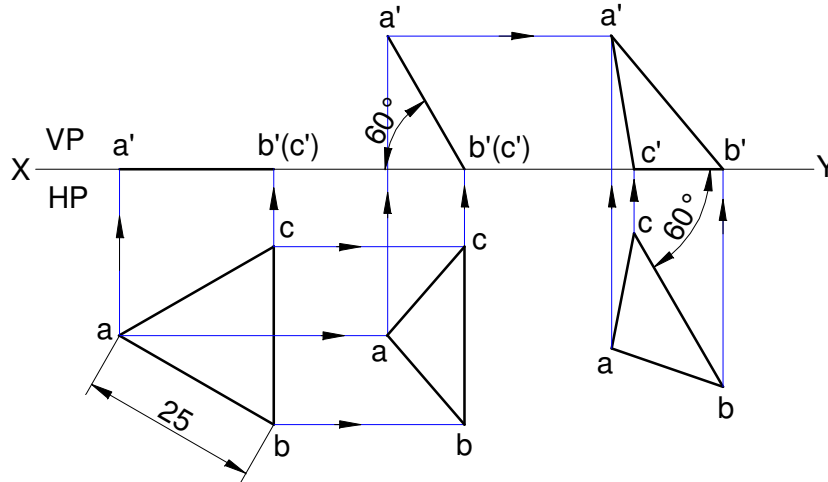

2 (4) A Triangular plane figure of sides 25 mm is resting on HP with one of its corners, such that the surface of the lamina makes an angle of 60 deg. with HP. If the side opposite to the corner on which the lamina rests makes an angle of 30 deg. with VP. Draw the top and front views in this position.

Solution:

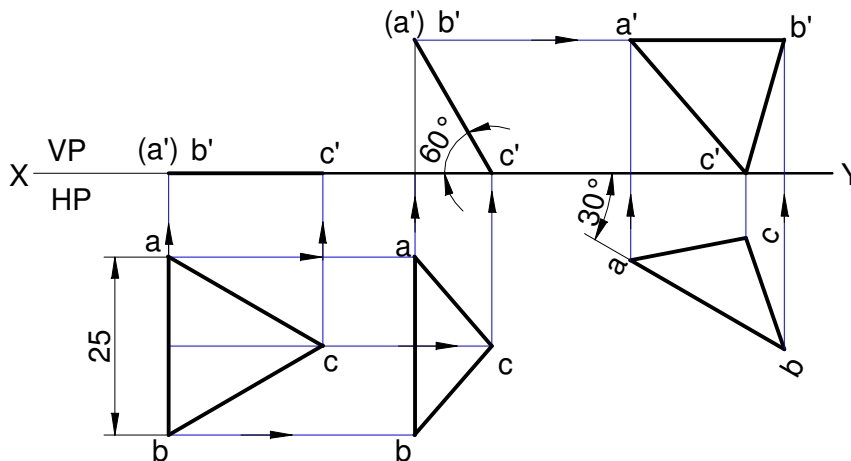

Projections of Planes

3. (6) A 30 - 60 deg. set square of 60 mm longest side is so kept such that the longest side is in HP making an angle of 30 deg. with VP. The set square itself is inclined at 45 deg. to HP. Draw the projections of the set square.

Solution:

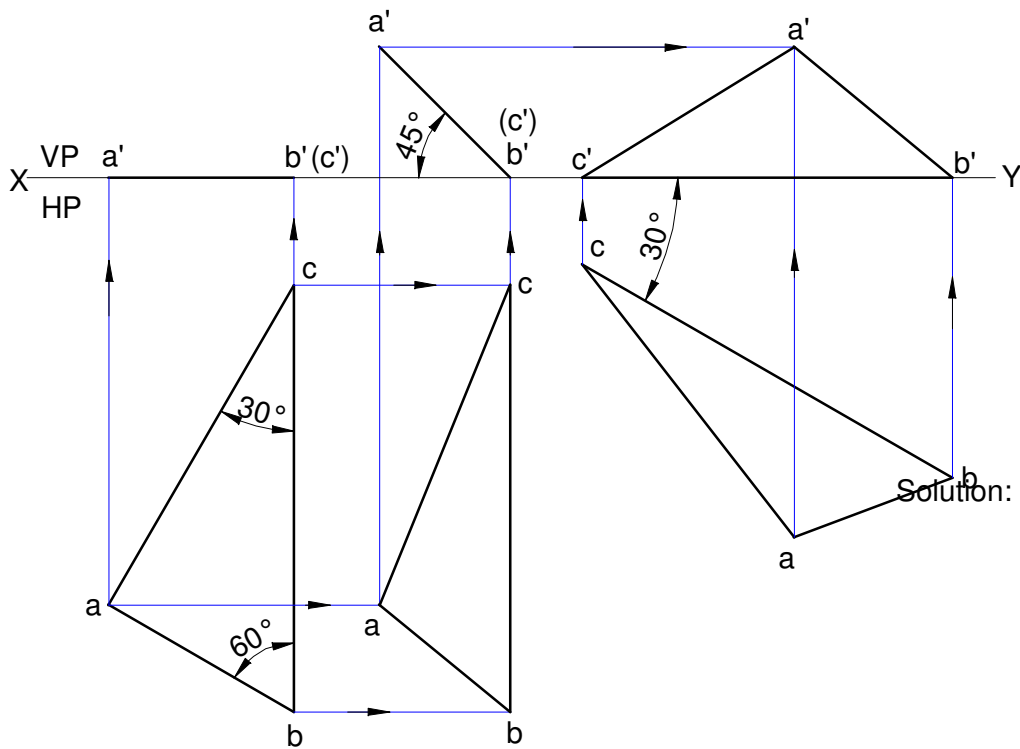

4. (8) A square lamina of 40 mm side rests on one of its sides on HP. The lamina makes 30 deg. to HP and the side on which it rests makes 45 deg. to VP. Draw its projections.

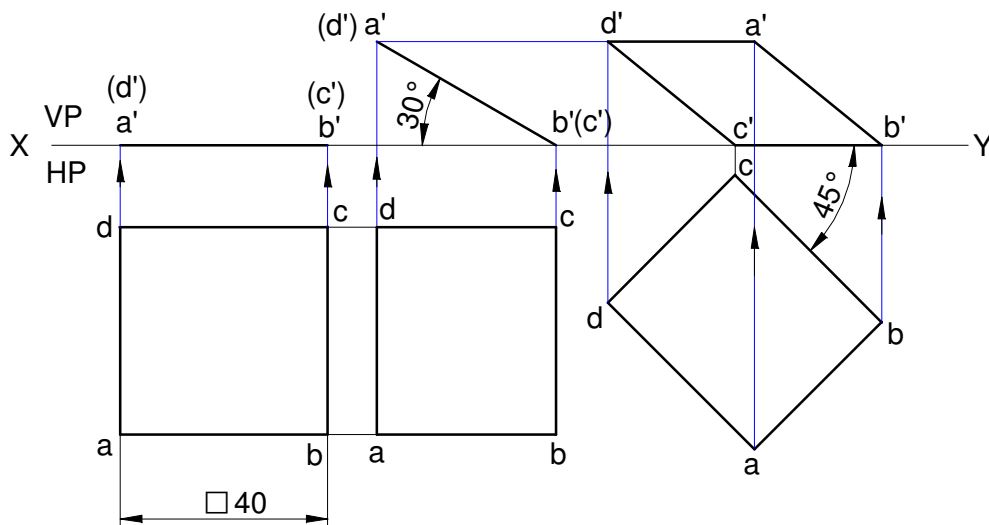

5. (12) A rectangular lamina of sides 20 mm X 30 mm rests on HP on one of its longer edges. The lamina is tilted about the edge on which it rests till its plane surface is inclined to HP at 45 deg. The edge on which it rests is inclined at 30 deg. to VP. Draw its projections of the lamina.

Solution:

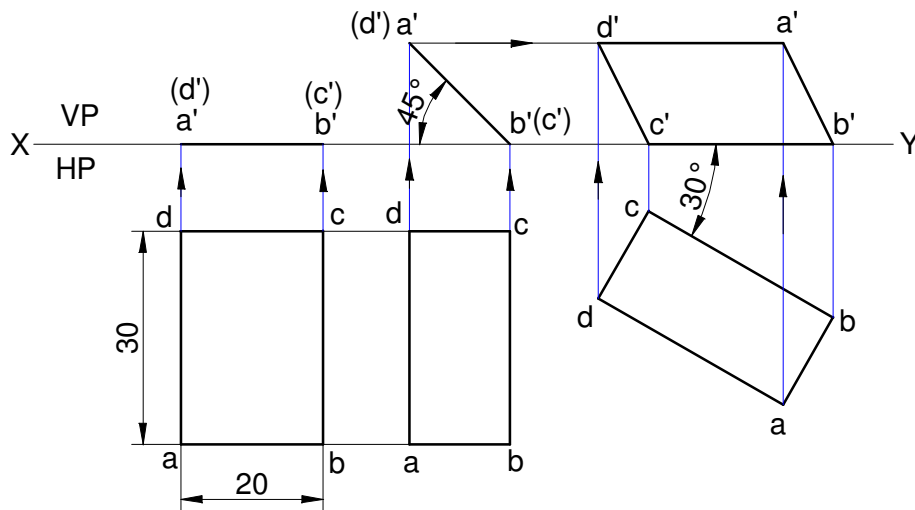

6. (19) A pentagonal lamina of edges 25 mm is resting on HP with one of its sides such that the surface makes an angle of 60 deg. with HP. The edge on which it rests is inclined at 45 deg. to VP. Draw its projections.

Solution:

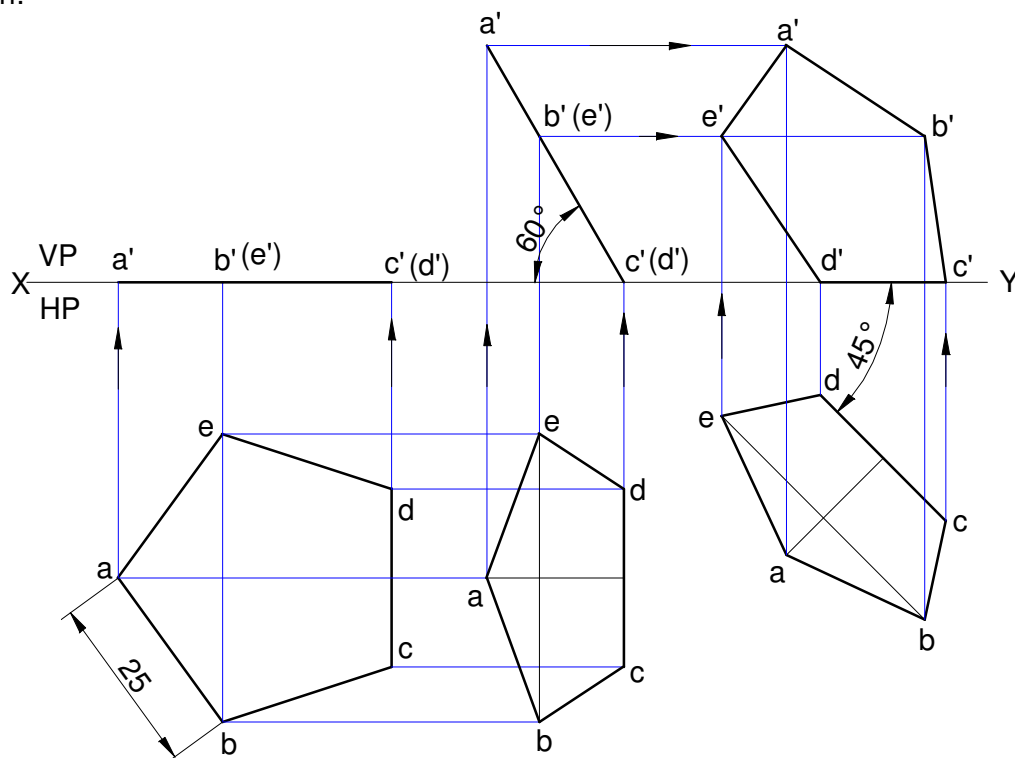

Projections of Planes

7. (20) Pentagonal lamina of edges 25 mm is resting on HP with one of its corners such that the plane surface makes an angle of 60 deg. with HP. The two of the edges containing the corner on which the lamina rests make equal inclinations with HP. When the edge opposite to the corner makes an angle of 45 deg. with VP and nearer to the observer. Draw the top and front views of the plane lamina in this position.

Solution:

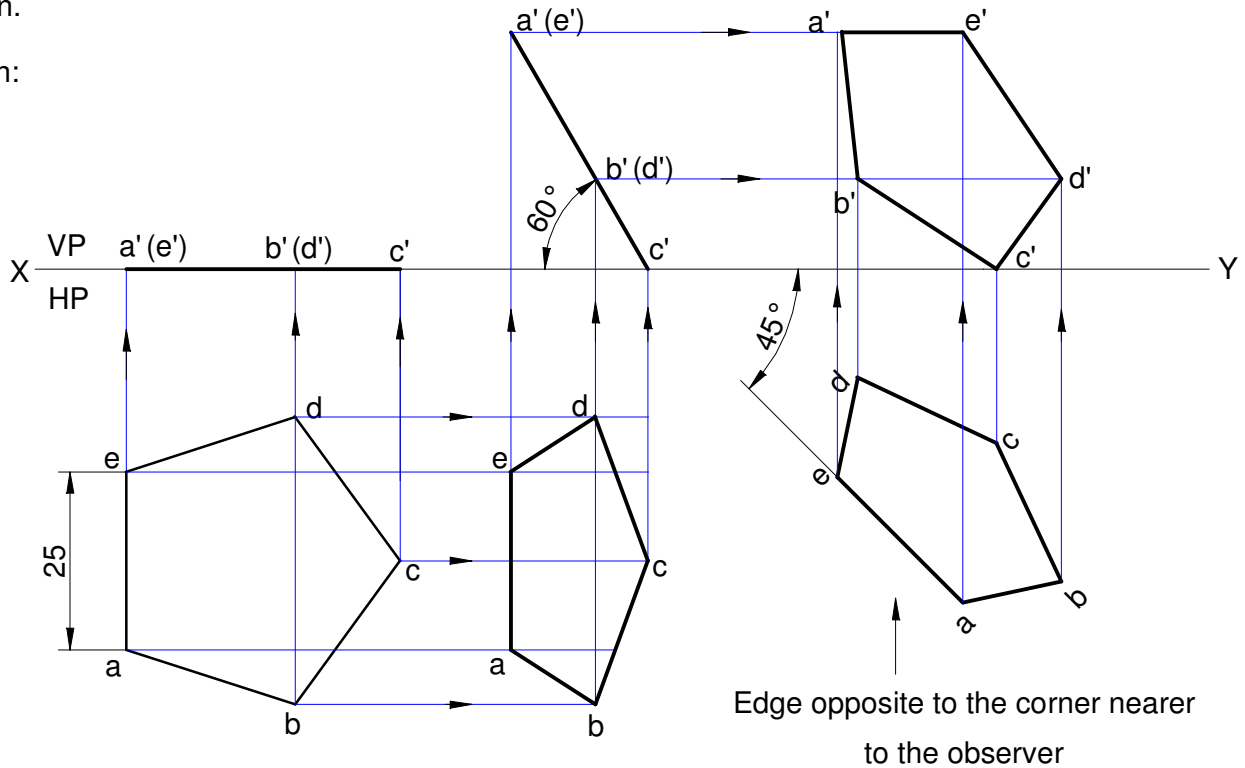

9. (40) A hexagonal lamina of sides 25 mm rests on one of its sides on HP. The lamina makes 45 deg. to HP and side on which it rests makes 30 deg. to VP. Draw its projections.

Solution:

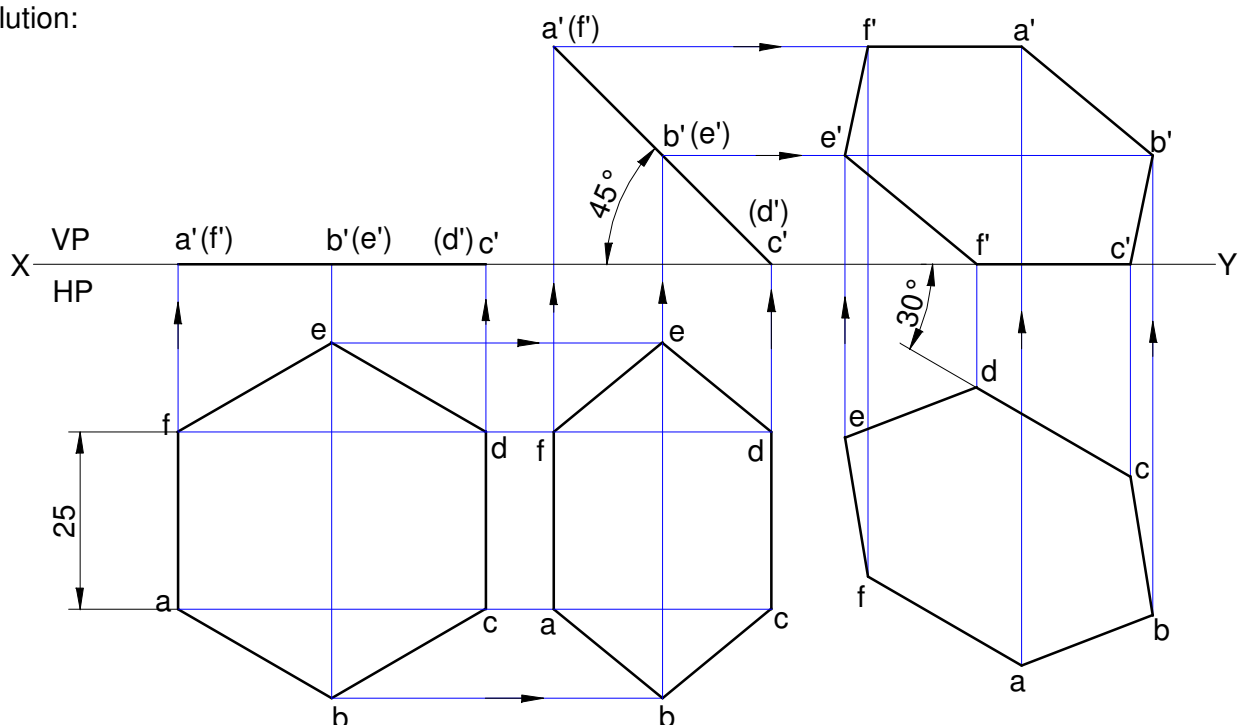

Projections of Planes

10. (2) An equilateral triangular lamina of 25 mm sides lies on one of its sides on HP. The lamina makes 45 deg. with HP and one of its medians is inclined at 40 deg. to VP. Draw the projections.

Solution:

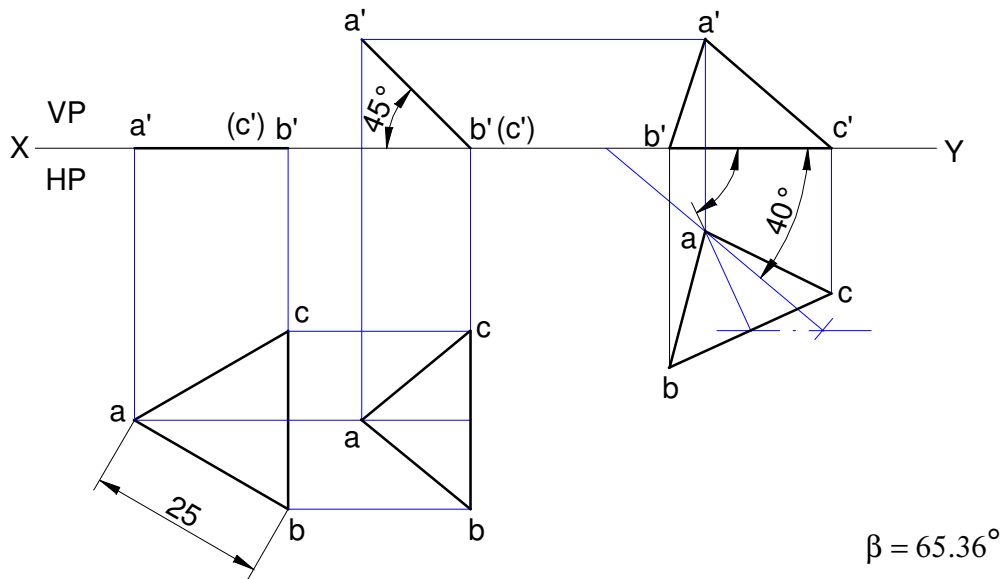

11. (9) A square plate of 30 mm sides rests on HP such that one of the diagonals is inclined at 30 deg. to HP and 45 deg. to VP. Draw its projections.

Solution:

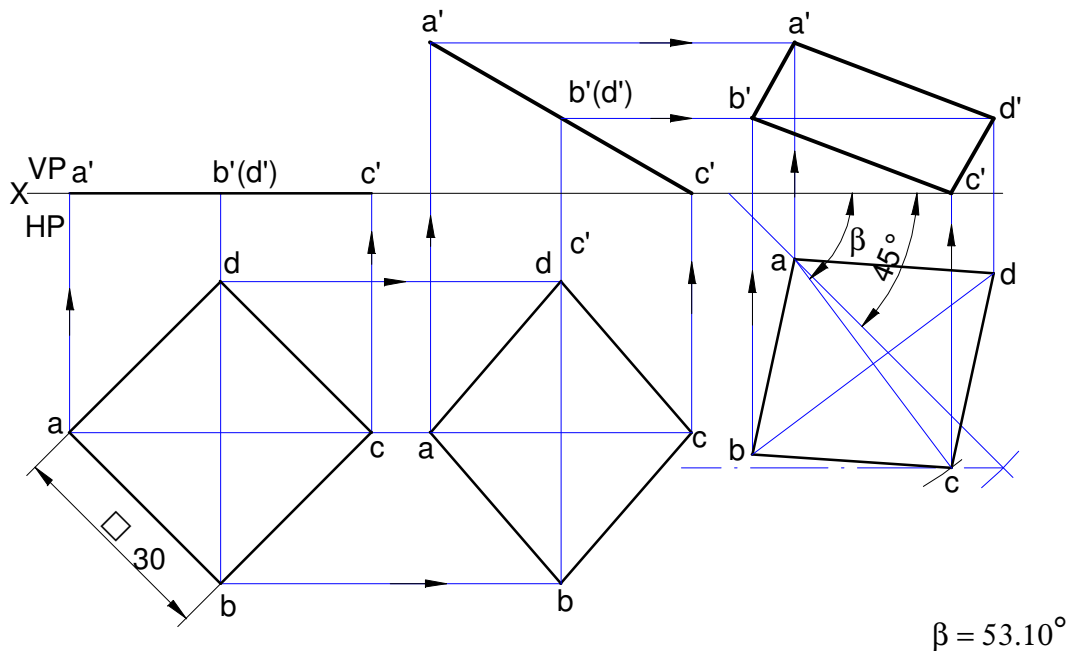

12. (23) A pentagonal lamina having edges 25 mm is placed on one of its corners on HP such that the perpendicular bisector of the edge passing through the corners on which the lamina rests is inclined at 30 deg. to HP and 45 deg. to VP. Draw the top and front views of the lamina.

Solution:

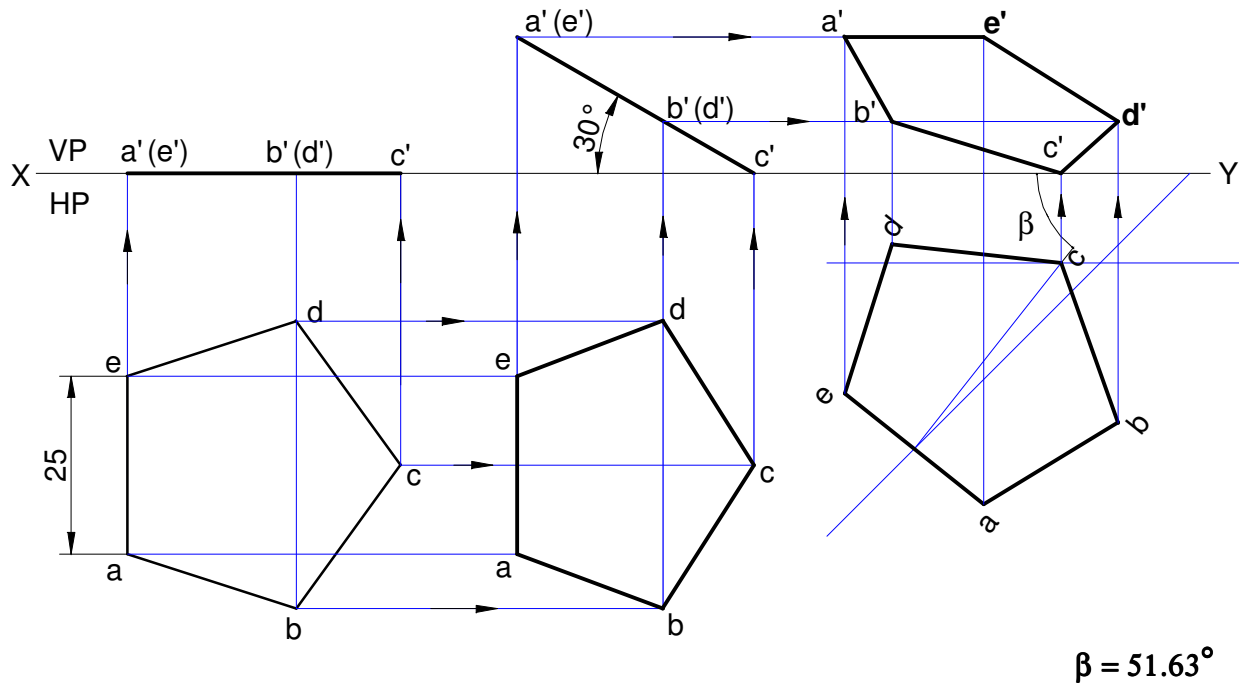

13. (41) A hexagonal lamina of sides 25 mm rests on one of its corners on HP. The lamina makes 45 deg. to HP and the diagonal passing through the corner on which it rests is inclined at 30 deg. to VP. Draw its projections.

Solution:

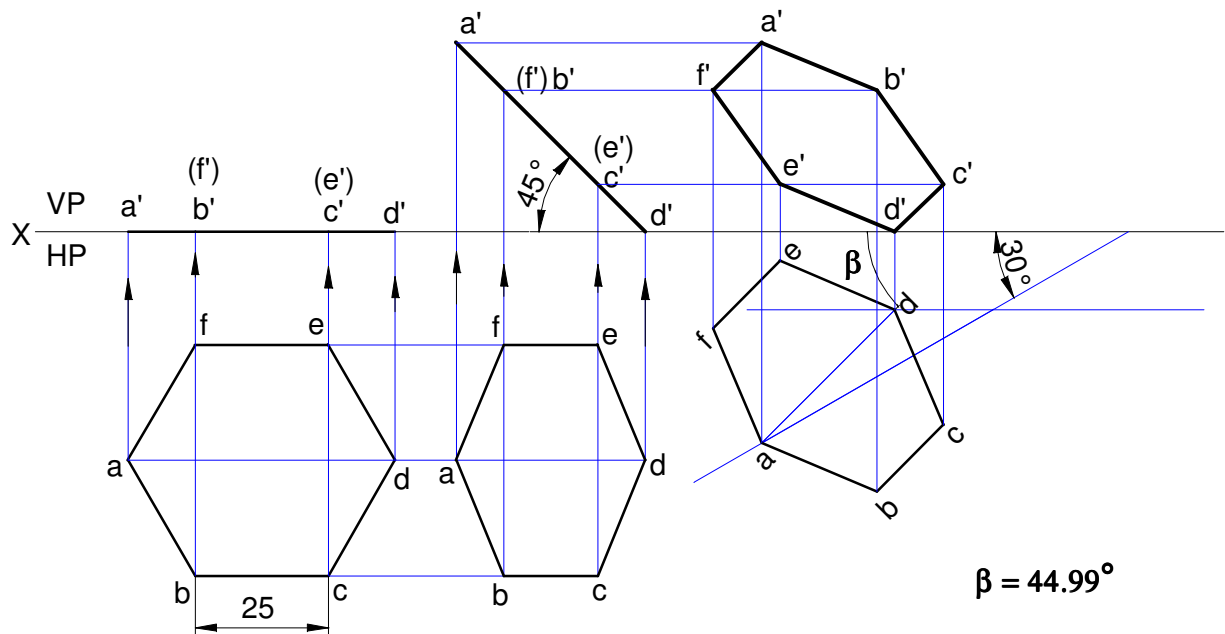

Projections of Planes

14. (48) A circular lamina of 50 mm diameter rests on HP such that one of its diameter is inclined at 30 deg. to VP and 45 deg. to HP. Draw its top and front views in this position.

Solution:

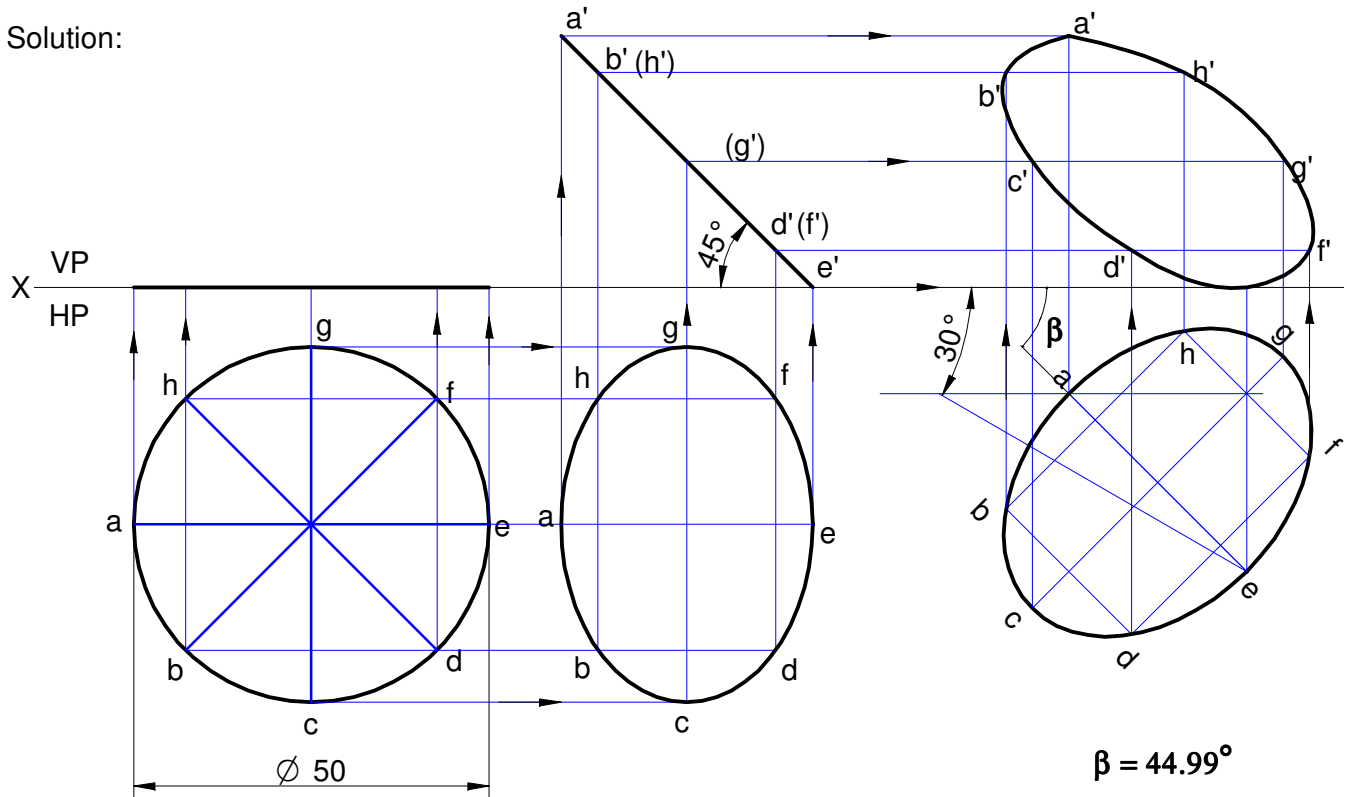

15. (50) A circular lamina of 30 mm diameter rests on VP such that one of its diameter is inclined at 30 deg. to VP and 45 deg. to HP. Draw its top and front views in this position.

Solution:

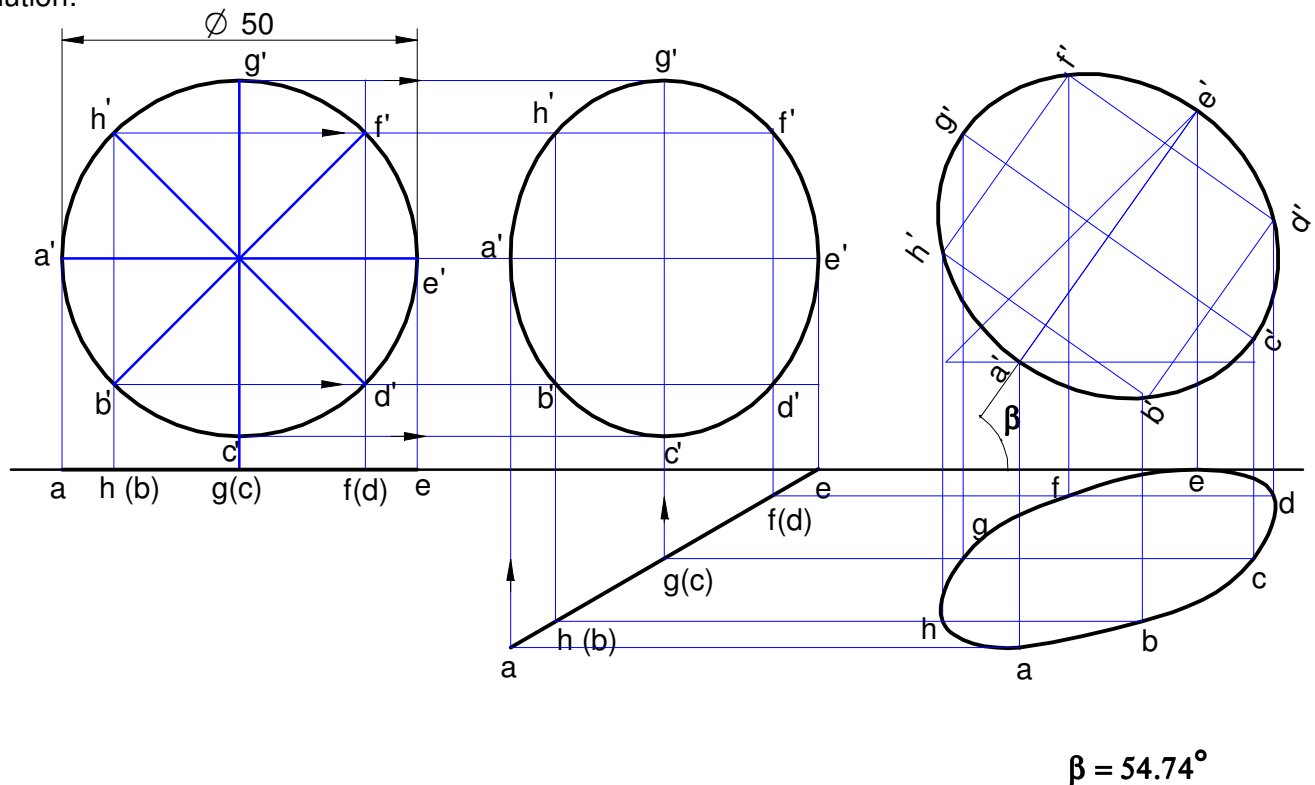

16. (3) A triangular lamina of 25 mm sides rests on one of its corners on VP such that the median passing through the corner on which it rests is inclined at 30 deg. to HP and 45 deg. to VP. Draw its projections.

Solution:

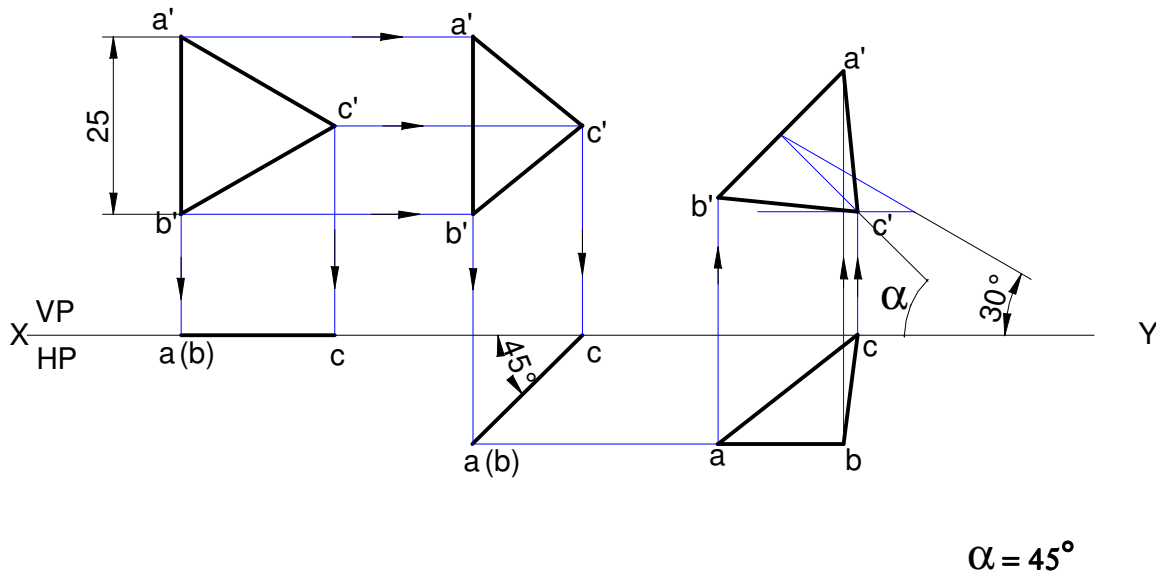

17. (31) A pentagonal lamina having edges 25 mm is placed on one of its corners on VP such that the surface makes an angle 30 deg. with VP and perpendicular bisector of the edge passing through the corner on which the lamina rests is inclined at 45 deg. to HP. Draw the top and front views of the lamina.

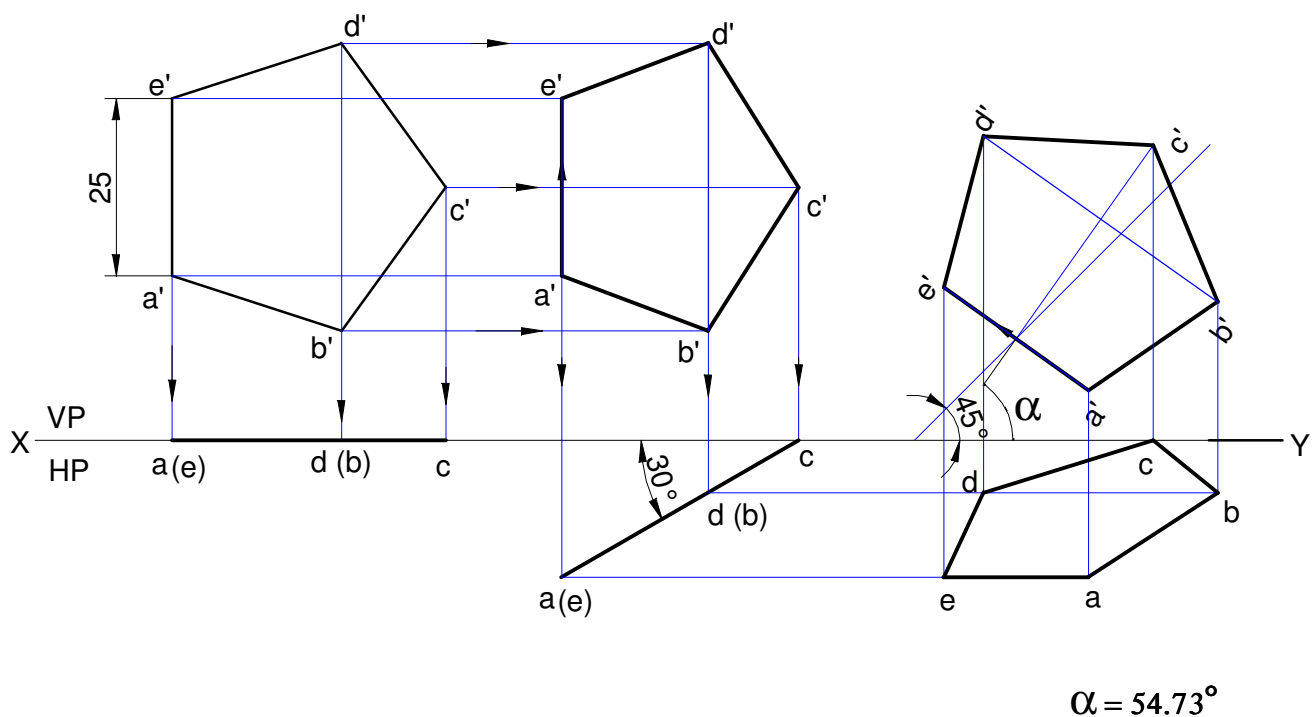

Projections of Planes

18. (38) A hexagonal lamina of sides 30 mm is resting on HP with one of its corners in VP and its surface inclined at an angle of 30 deg. with VP. The diagonal passing through that corner which is in VP is inclined at an angle 45 deg. to HP. Draw the projections of the lamina.

Solution:

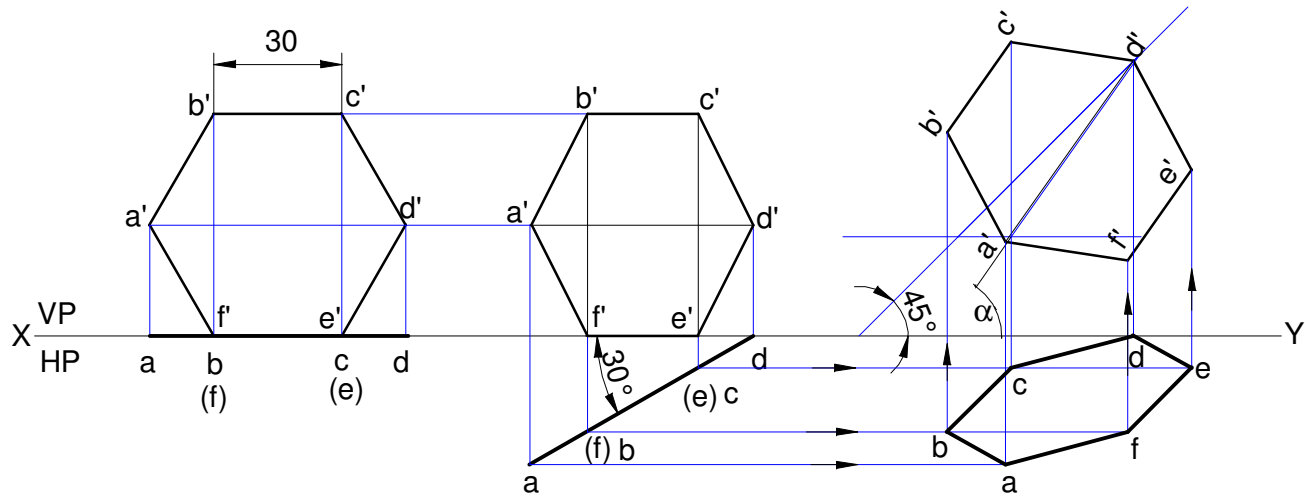

$$\alpha = 54.72^\circ$$

19. (10) A square lamina ABCD of 40 mm side rests on corner C such that diagonal AC appears to be at 45 deg. to VP. The two sides BC and CD containing that corner C make equal inclination with HP. The surface of the lamina makes 30 deg. with HP. Draw its top and front views.

Solution:

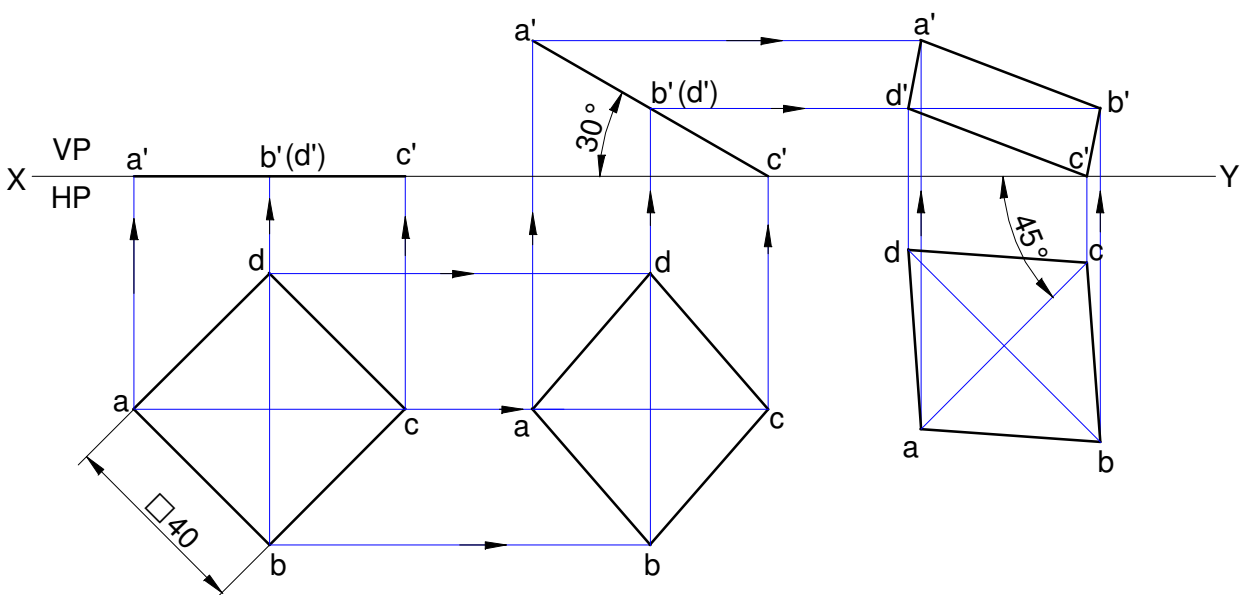

20. (27) A pentagonal lamina having edges 25 mm is placed on one of its corners on HP such that the surface makes an angle 30 deg. with HP and perpendicular bisector of the edge passing through the corner on which the lamina rests appears to be inclined at 30 deg. to VP. Draw the top and front views of the lamina.

Solution:

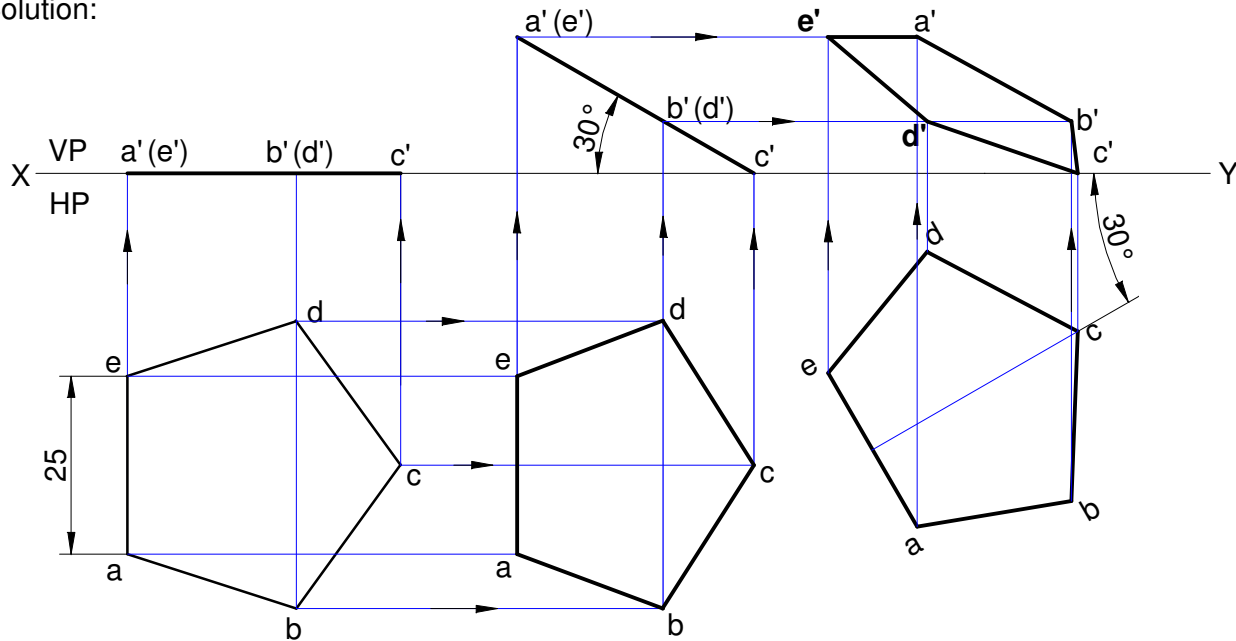

21. (42) A hexagonal lamina of sides 25 mm rests on one of its corners on HP. The lamina makes 45 deg. to HP and the diagonal passing through the corner on which it rests appears to be inclined at 30 deg. to VP. Draw its projections.

Solution:

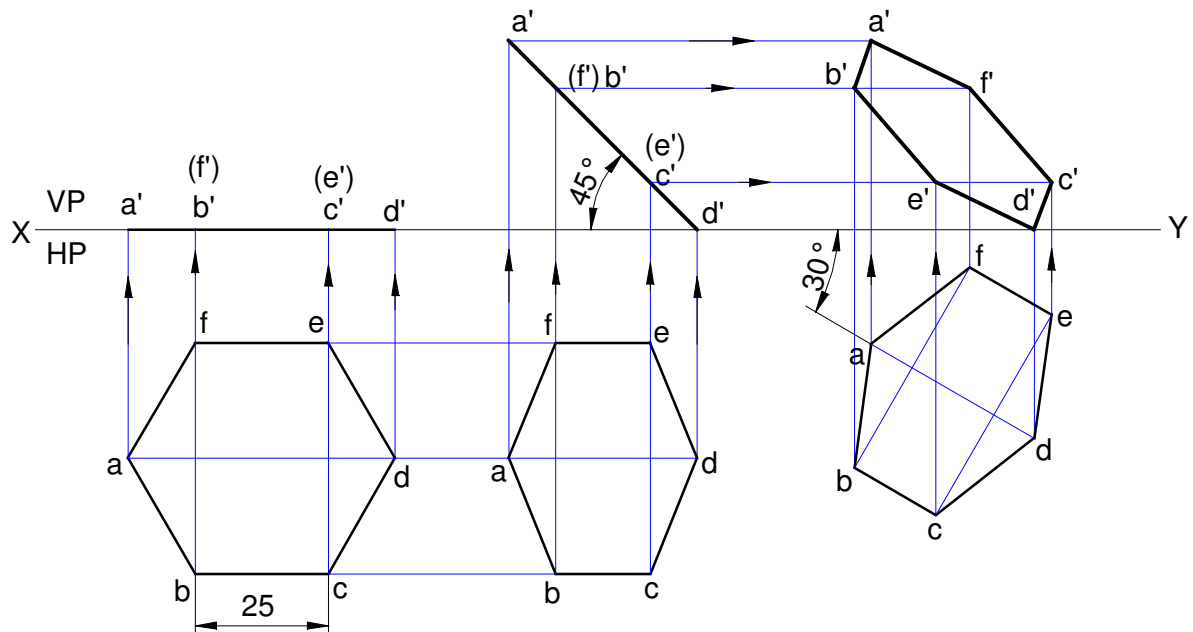

22 (46) Draw the projections of a circular plate of negligible thickness of 50 mm diameter resting on HP on a point A on the circumference, with its plane inclined at 45 deg. to HP and the top view of the diameter passing through the resting point makes 60 deg. with VP.

Solution:

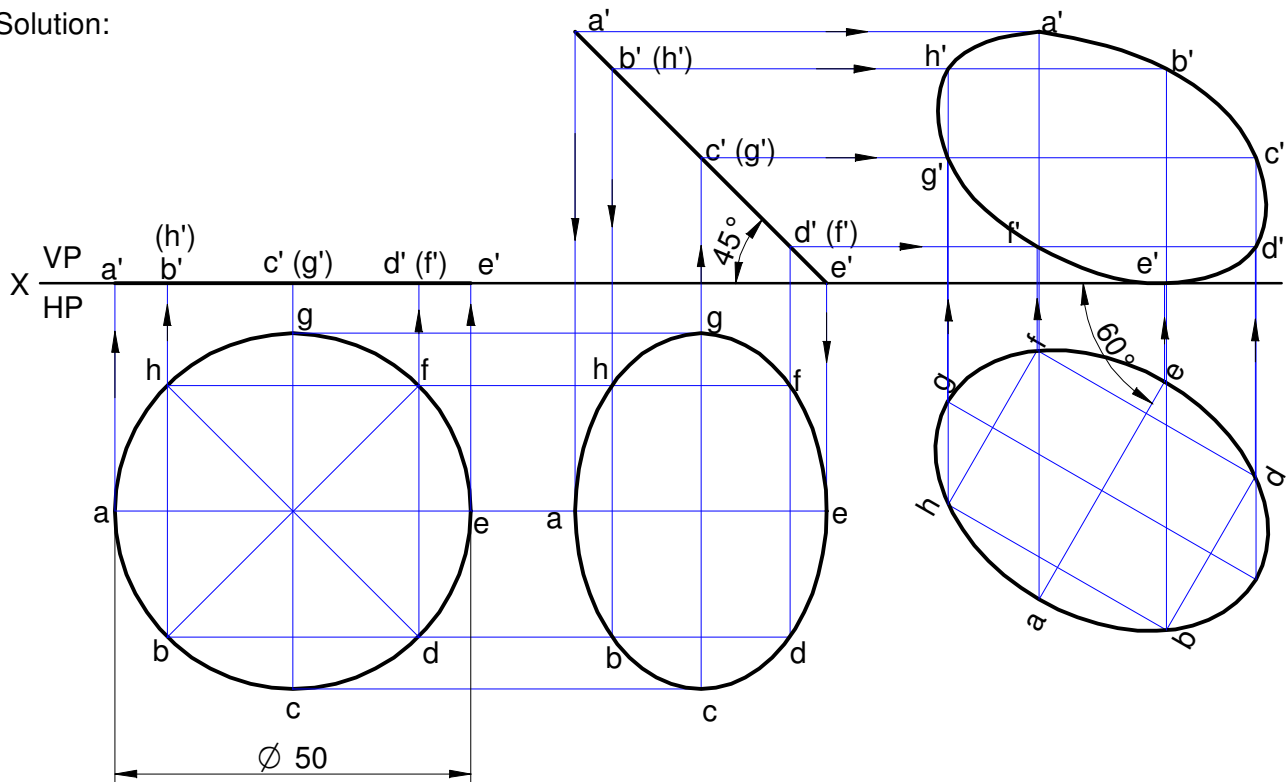

23. (30) A pentagonal lamina having edges 25 mm is placed on one of its corners on VP such that the surface makes an angle of 30 deg. with VP and perpendicular bisector of the edge passing through the corner on which the lamina rests appears to be inclined at 30 deg. to HP. Draw the top and front views of the lamina.

Solution:

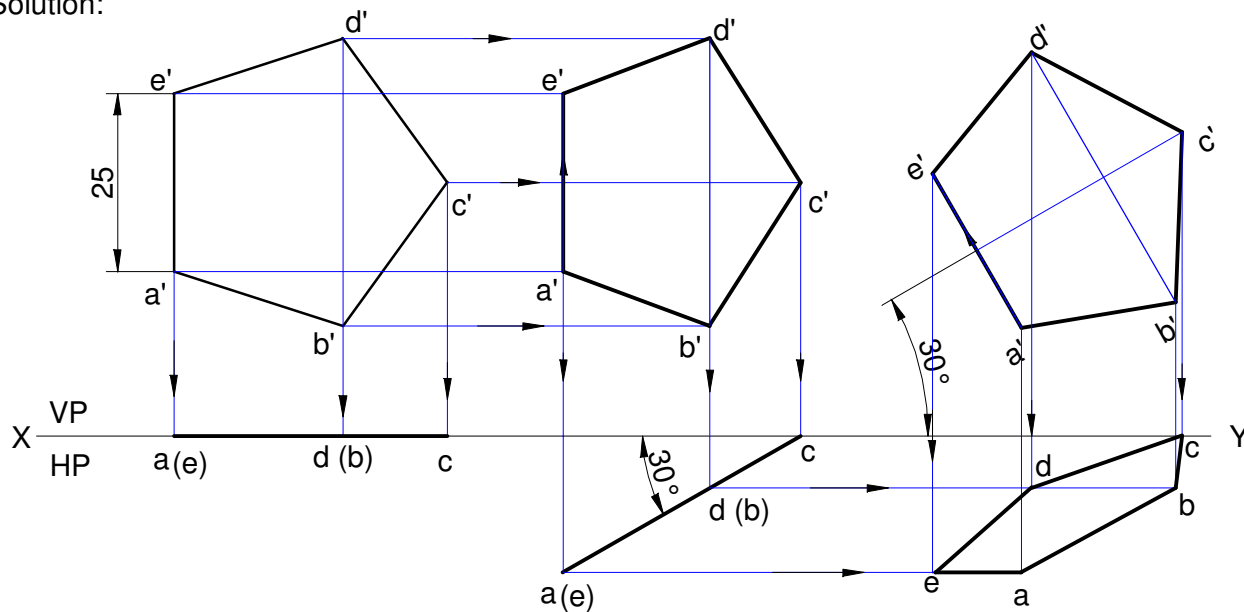

Projections of Planes

24. (38) A hexagonal lamina of sides 30 mm is resting on HP with one of its corners in VP and its surface inclined at an angle of 30 deg. with VP. The diagonal passing through that corner which is in VP is inclined at an angle 40 deg. to HP. Draw the projections of the lamina.

Solution:

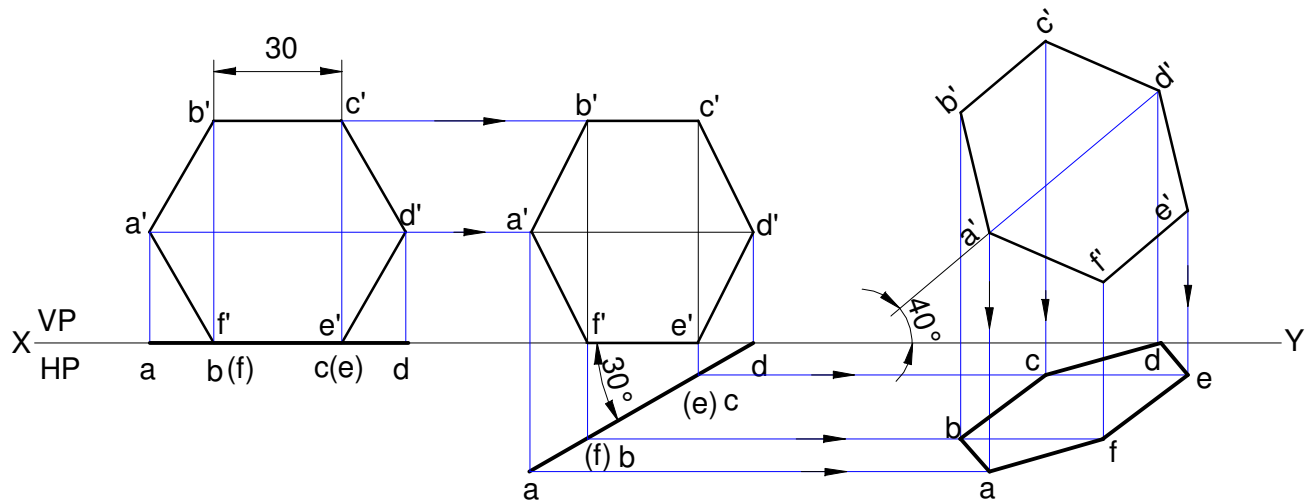

25. (5) A triangular plane lamina of sides 25 mm is resting on HP with one of its corners touching it, such that the side opposite to the corner on which it rests is 15 mm above HP and make an angle of 30 deg. with VP. Draw the top and front views in this position. Also determine the inclination of the lamina to the reference plane.

Solution:

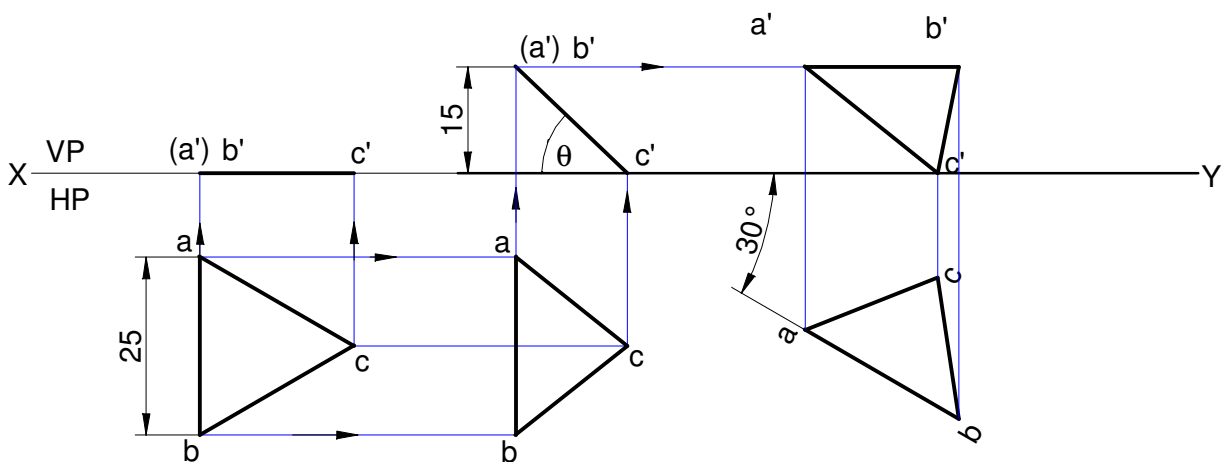

ANSWER

$$\theta = 43.86^\circ$$

26. (21) A pentagonal lamina of edges 25 mm is resting on HP with one of its corner such that the edge opposite to this corner is 20 mm above HP & makes an angle of 45 deg. with VP. Draw the top and front views of the plane lamina in this position. Determine the inclination of the lamina with HP.

Solution:

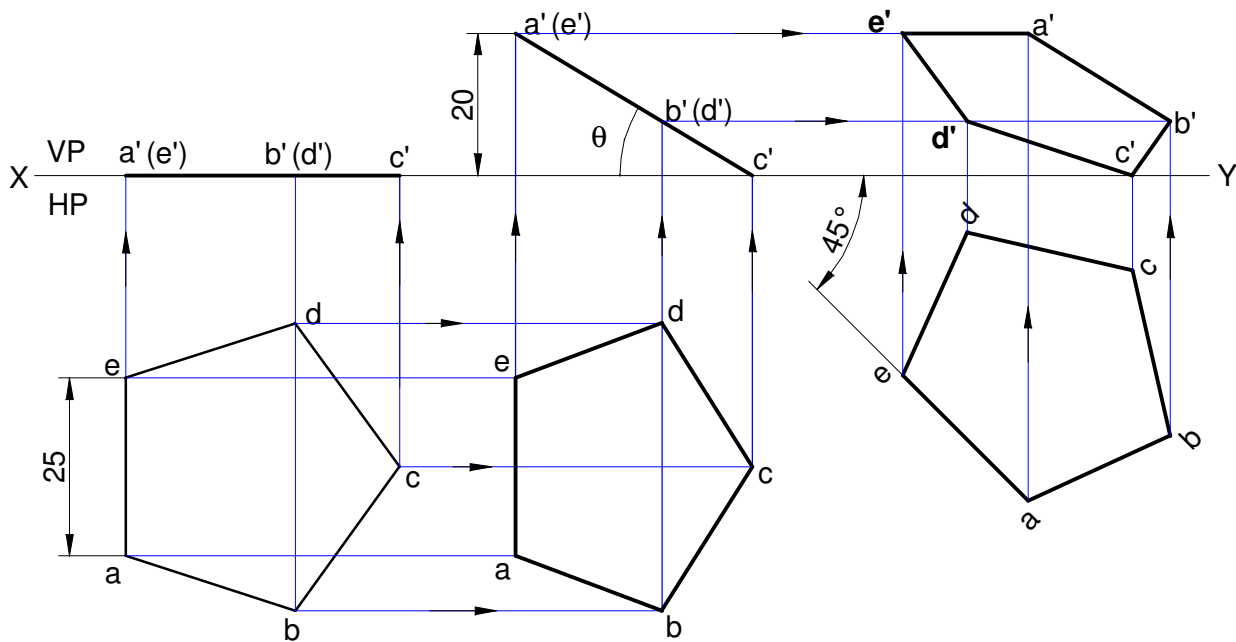

ANSWER

$$\theta = 31.32^\circ$$

27. (45) A hexagonal lamina of sides 25 mm rests on one of its corners on HP. The corner opposite to the corner on which it rests is 35 mm above HP and the diagonal passing through the corner on which it rests is inclined at 30 deg. to VP. Draw its projections. Find the inclination of the surface with HP.

Solution:

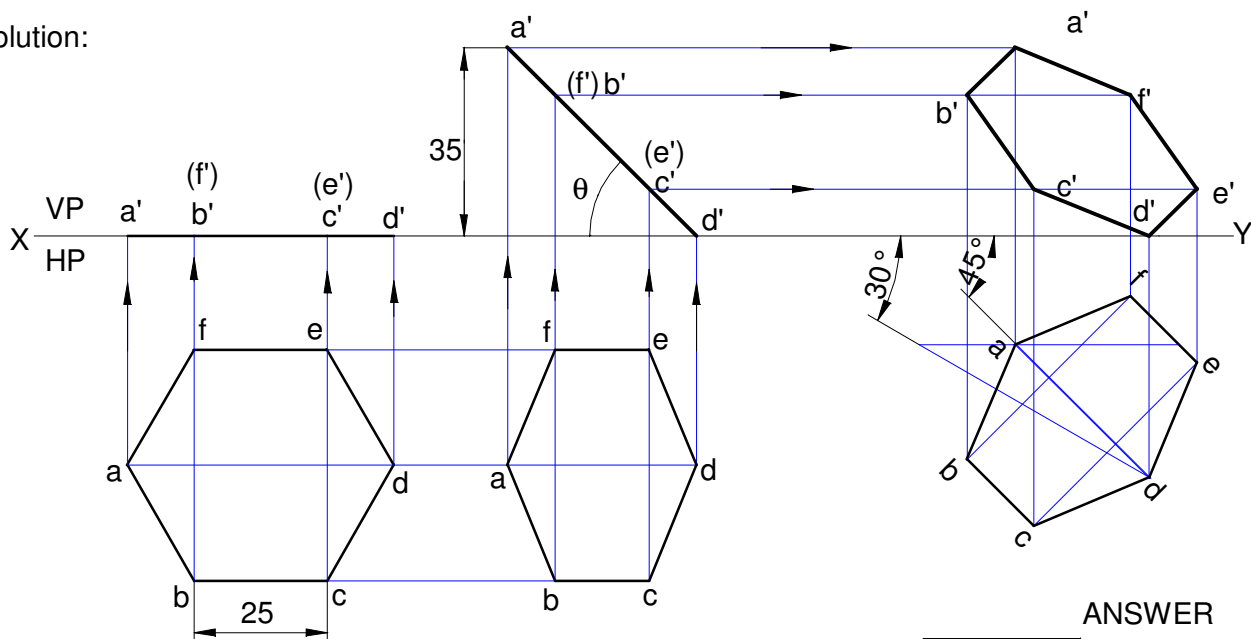

ANSWER

$$\theta = 43.43^\circ$$

$$\beta = 44.99^\circ$$

28. (44) A hexagonal lamina of sides 25 mm rests on one of its sides on VP. The side opposite to the side on which it rests is 30 mm in front of VP and the side on which it rests makes 45 deg. to HP. Draw its projections. Also determine the inclination of the lamina with the reference plane.

Solution:

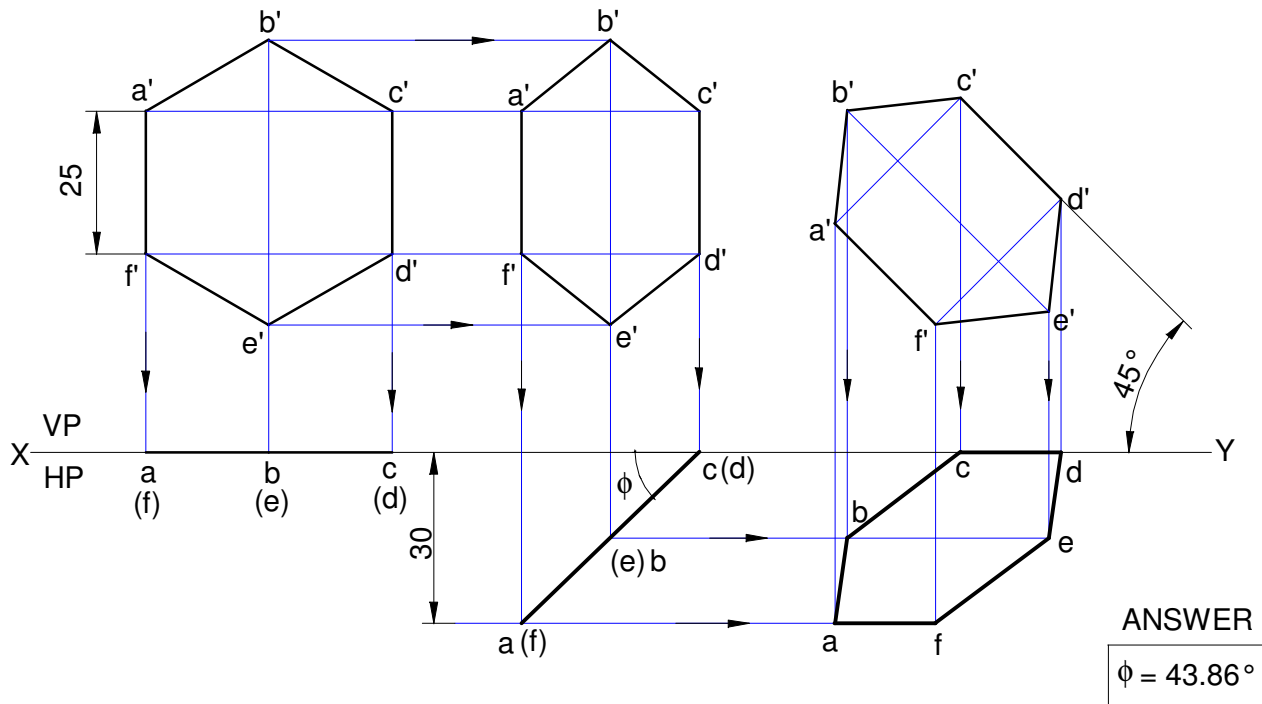

29. (14) A rectangular lamina of 35 mm X 20 mm rests on HP one of its shorter edges. The lamina is rotated about the edge on which it rests till it appears as a square in the top view. The edge on which the lamina rests is inclined at 30 deg. to VP. Draw its projections and find its inclination to HP.

Solution:

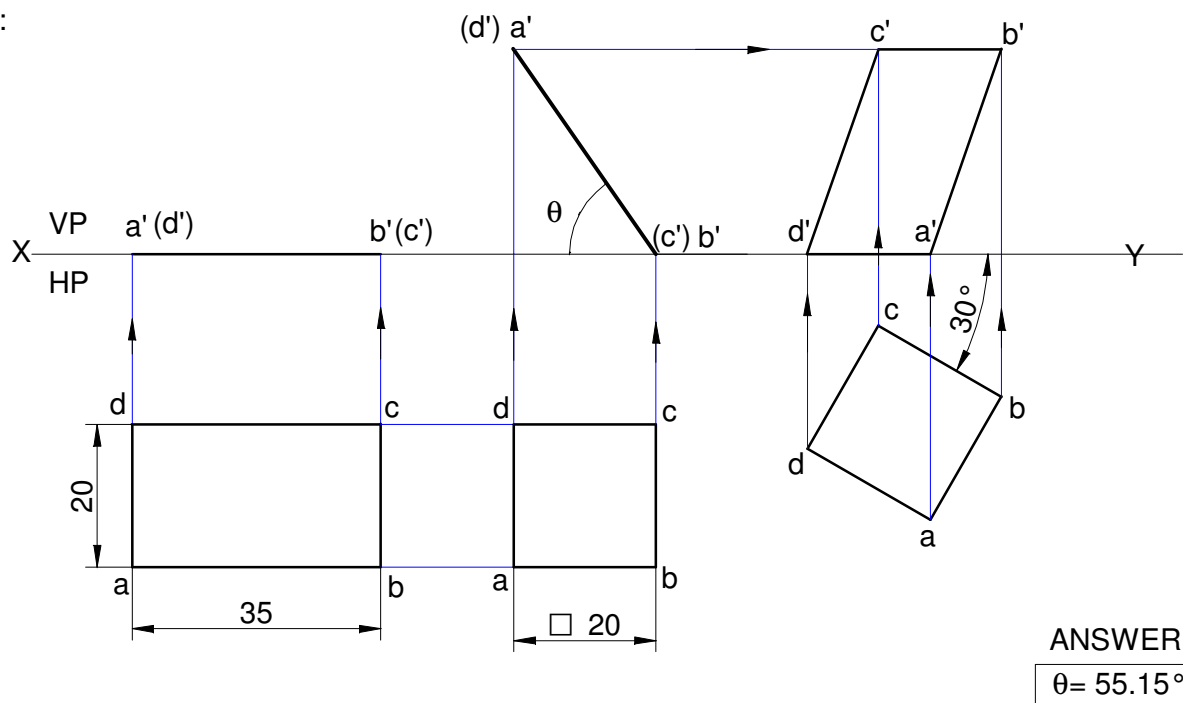

Projections of Planes

30. (13) A rectangular lamina of 35 X 20 mm rests on HP on one of its shorter edges. The lamina is rotated about the edge on which it rests till it appears as a square in the top view. The edge on which the lamina rests being parallel to both HP and VP. Draw its projections and find its inclinations to HP and VP.

Solution:

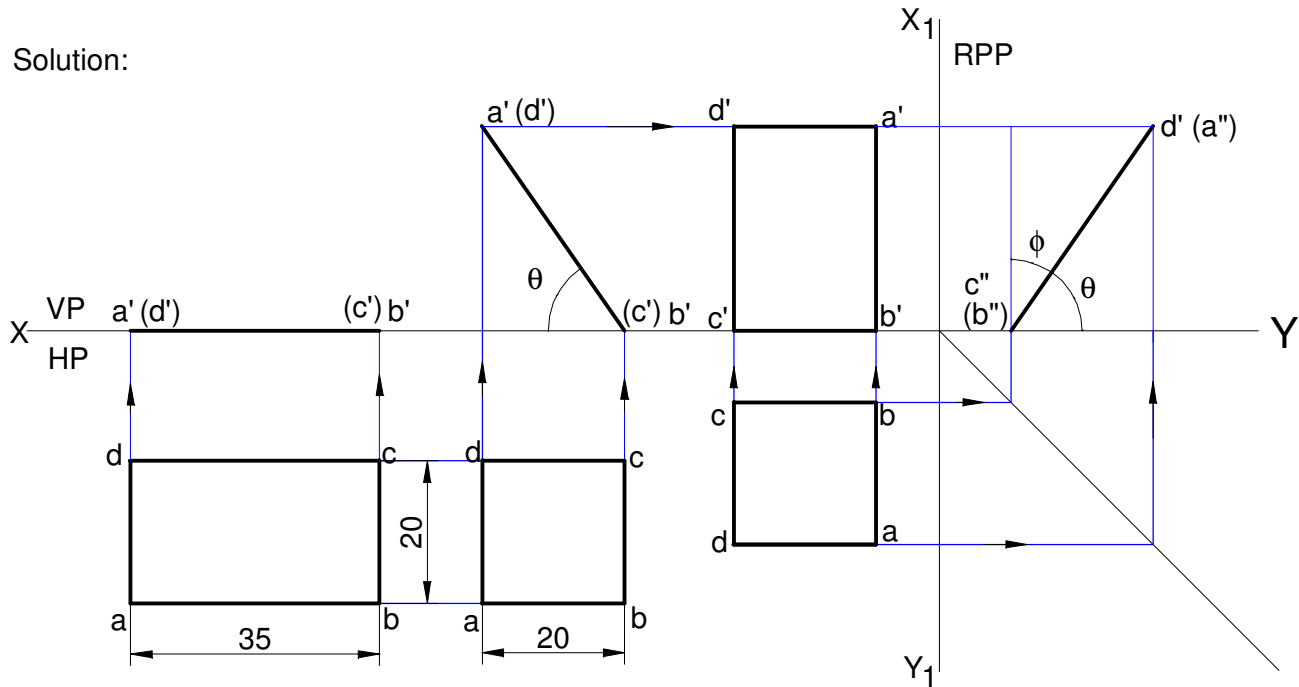

ANSWERS: Inclination of Lamina to HP (θ) = 55.15° Inclination of Lamina to VP (ϕ) = 34.85°

31. (18) A rectangular plate of negligible thickness of size 35 X 20 mm has one of its shorter edges in VP with that edge inclined at 40 deg. to HP. Draw the top view if its front view is a square of side 20 mm.

Solution:

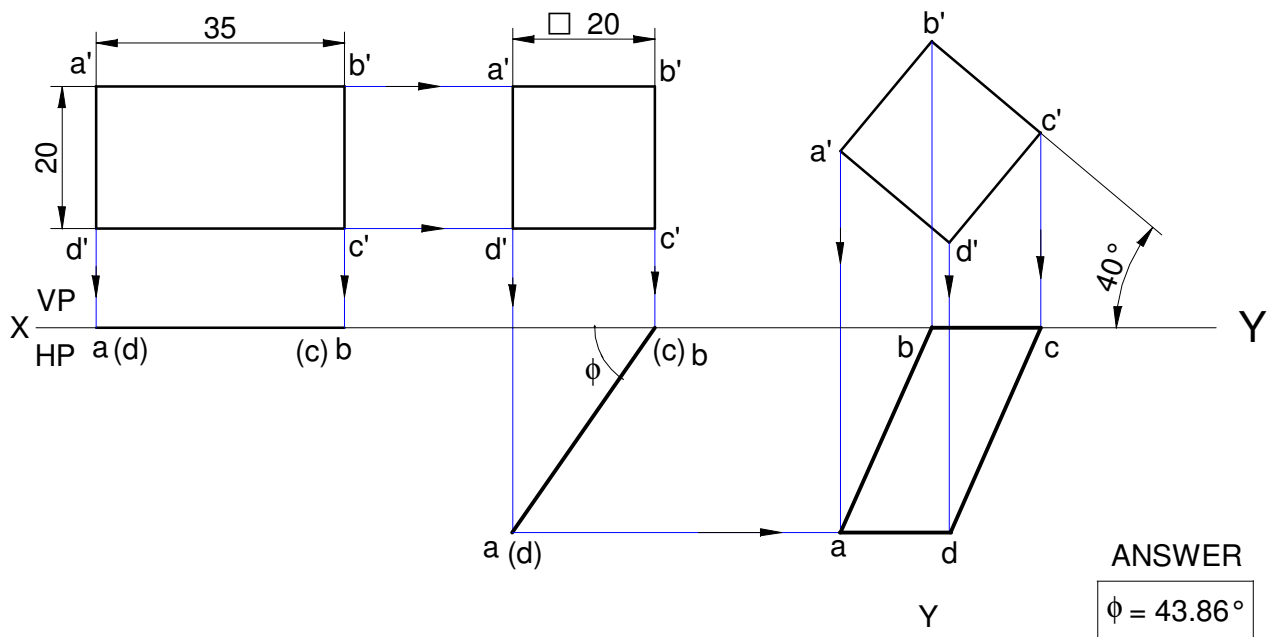

ANSWER

$\phi = 43.86^\circ$

32. (16) The front view of a rectangular lamina of sides 30 mm X 20 mm is a square if 20 mm sides. Draw the projections and determine the inclination of the surface of the lamina with HP and VP.

Solution:

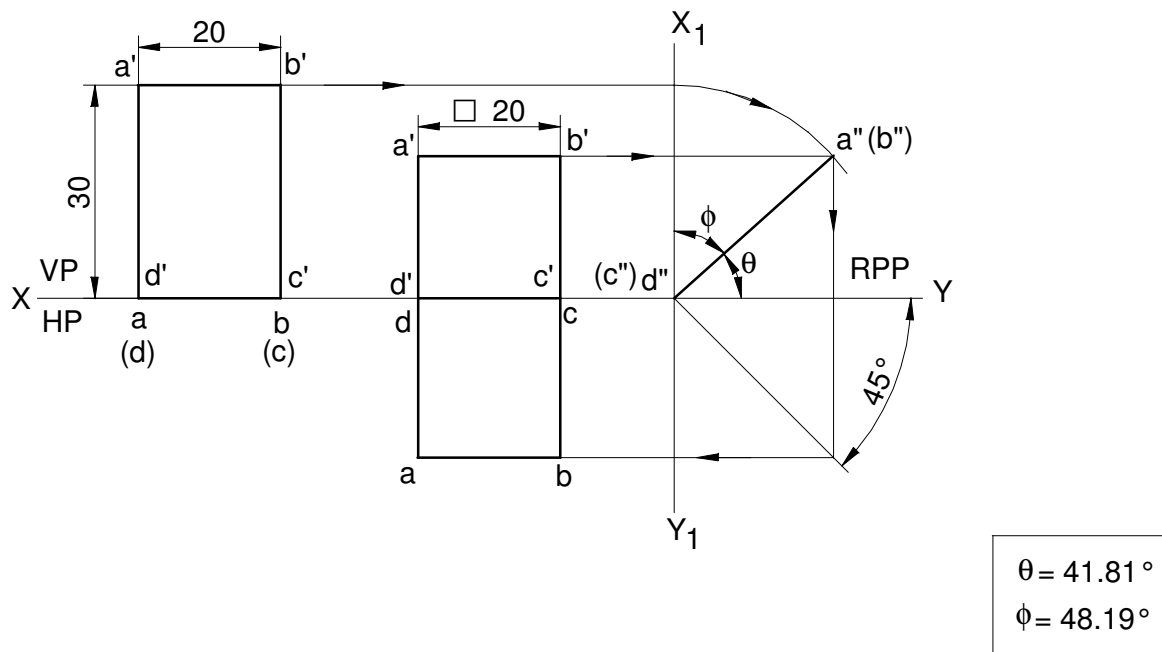

33. (11) The top view of a square lamina of side 30 mm is a rectangle of sides 30 mm X 20 mm with a longer side of the rectangle being parallel to both HP and VP. Draw the top and front views of the square lamina. What is the inclination of the lamina with HP and VP.

Solution:

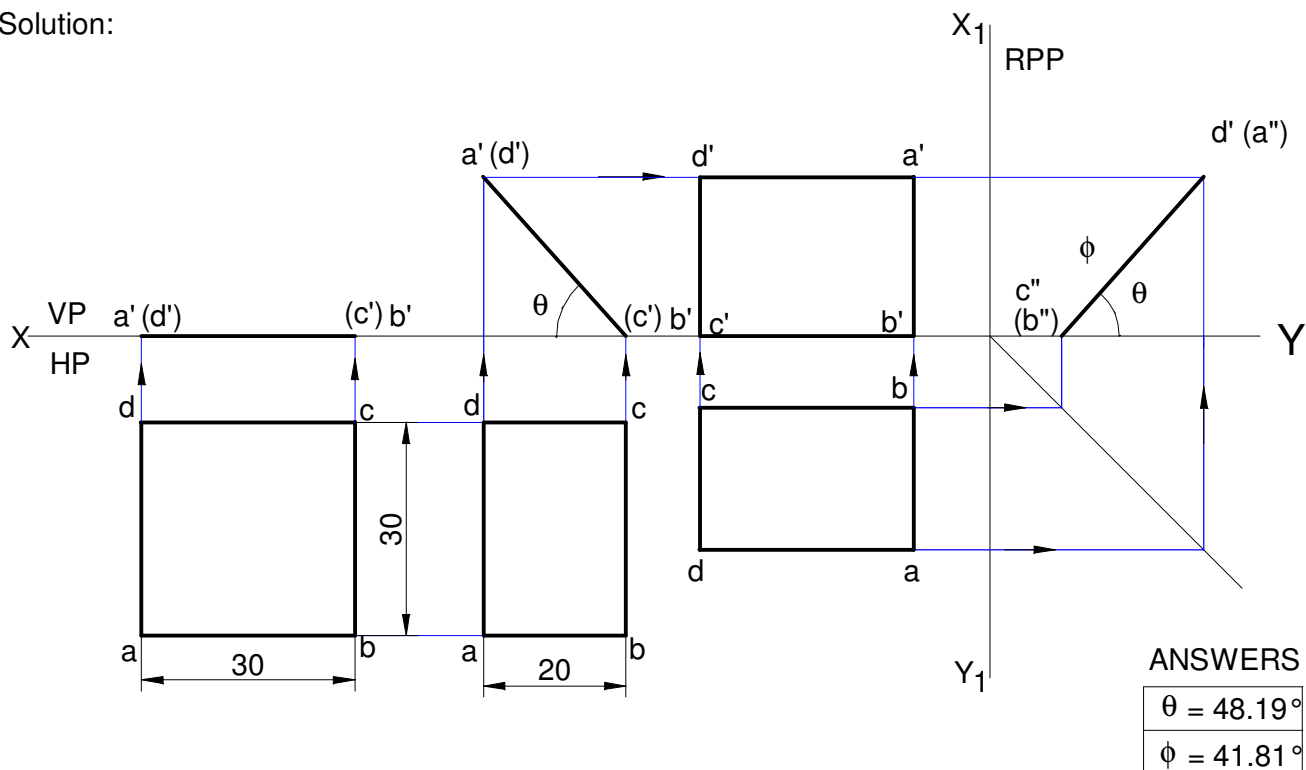

34. (22) A pentagonal lamina of sides 25 mm is resting on one of its edges on HP with the corner opposite to that edge touching VP. This edge is parallel to VP and the corner, which touches VP is at a height of 15 mm above HP. Draw the projections of the lamina and determine the inclination of the lamina with HP and VP and the distance at which the parallel edge lies from VP.

Solution:

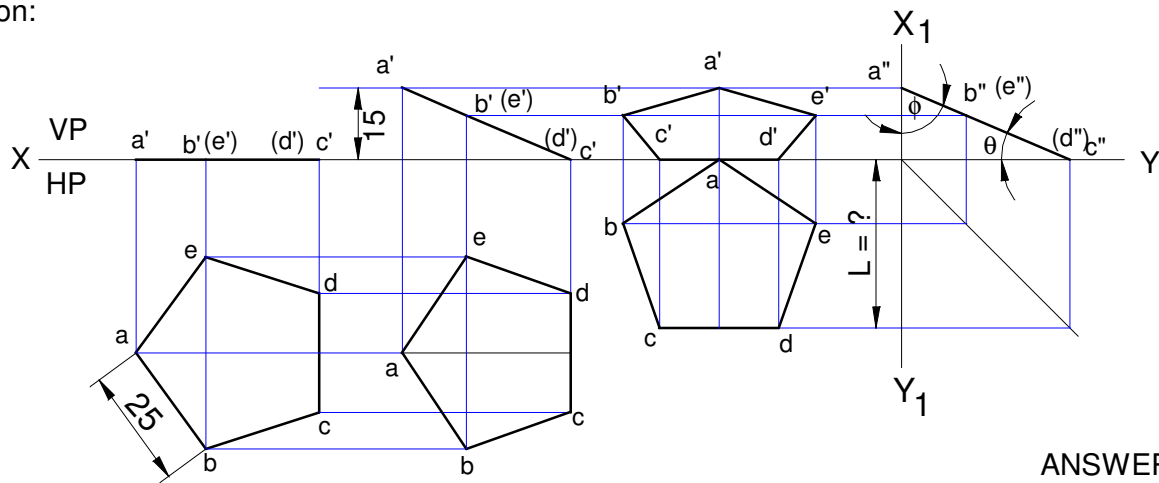

ANSWERS

$\theta = 22.95^\circ$
$\phi = 67.05^\circ$

35 (24) A pentagonal lamina of sides 25 mm is having a side both on HP and VP. The corner opposite to the side on which it rests is 15 mm above HP. Draw the top and front views of the lamina.

Solution:

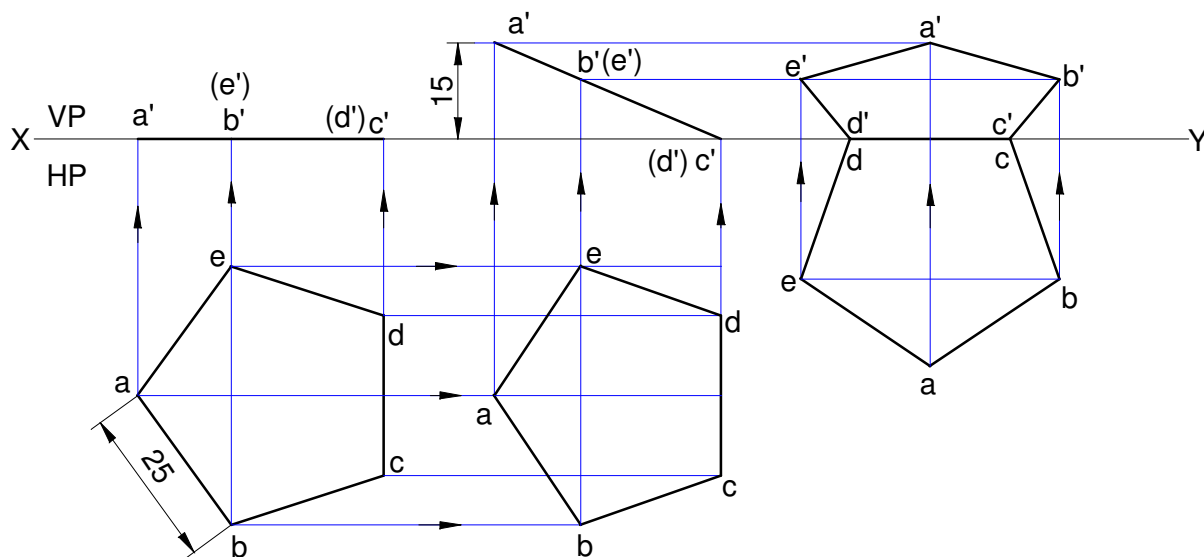

Projections of Planes

36. (35) A regular hexagonal lamina of side 30 mm is lying in such a way that one of its sides touches both the reference planes. If the side opposite to the side on which it rests is 45 mm above HP. Draw the projections of the lamina.

Solution:

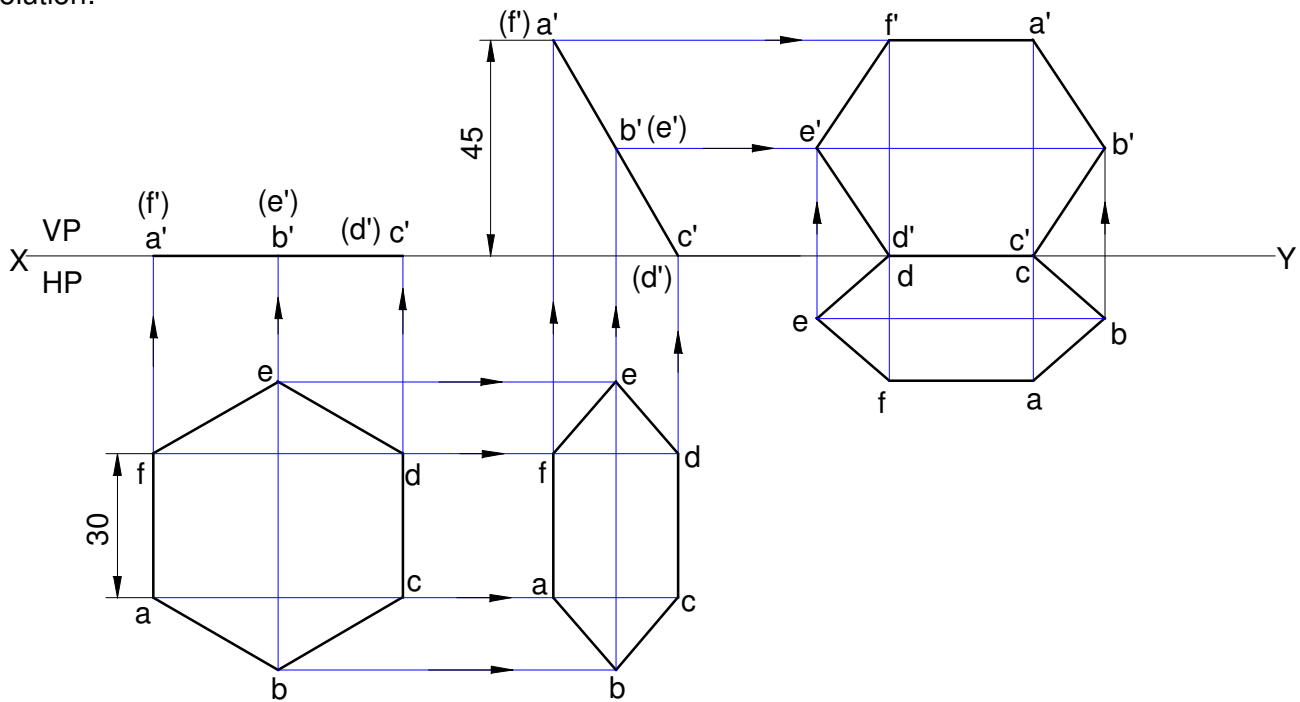

37. (25) A pentagonal lamina of sides 25 mm is having a side on both HP and VP. The surface of the lamina is inclined at an angle of 60 deg. with HP. Draw the top and front views of the lamina.

Solution:

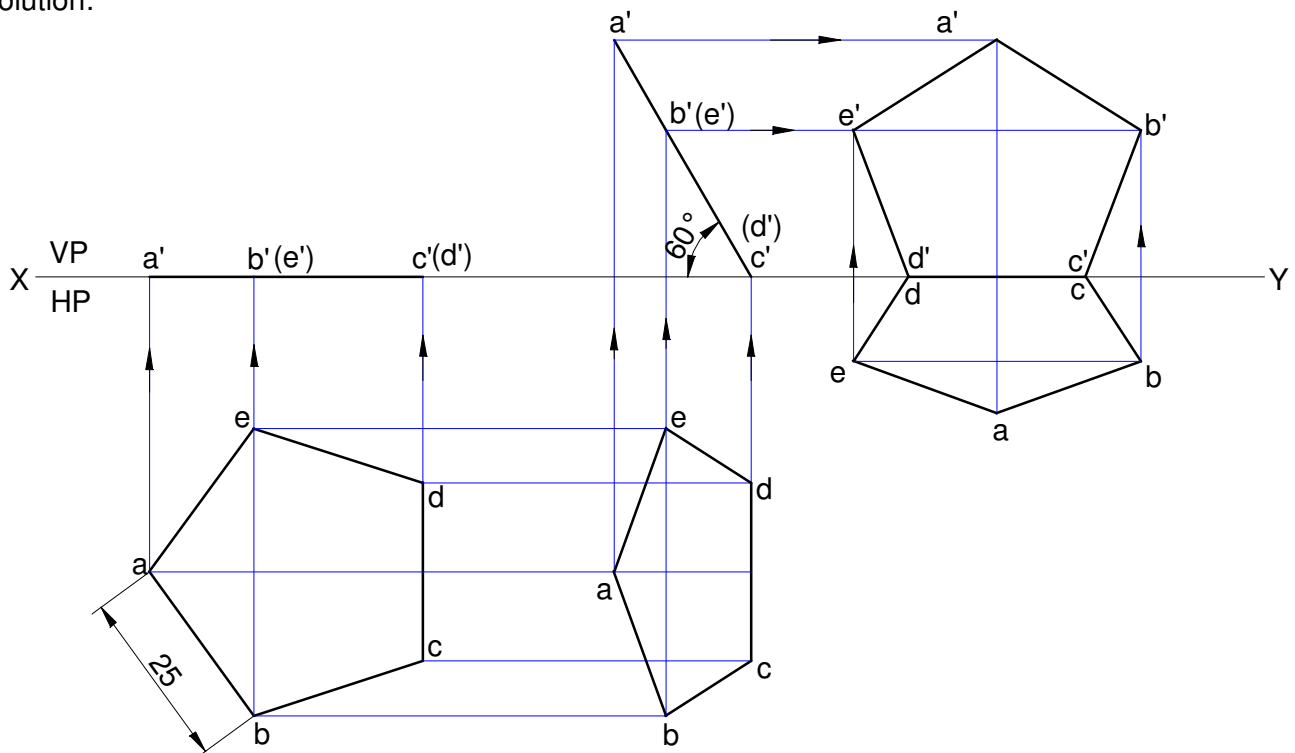

38. (26) A regular pentagonal lamina of 25 mm side is resting on one of its corner on HP while the side opposite to this corner touches VP. If the lamina makes an angle of 30 deg. with HP and 60 deg. with VP. Draw the projections of the lamina.

Solution:

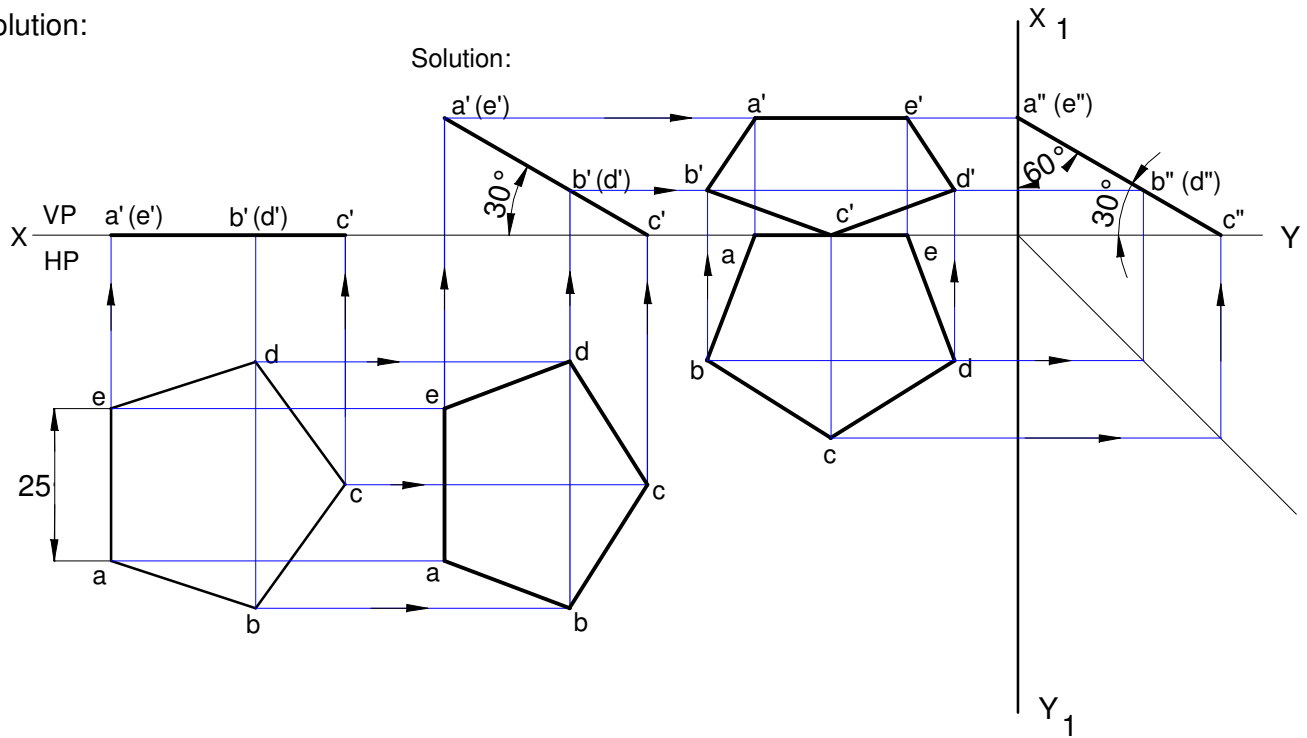

39. (28) A regular pentagonal lamina of 25 mm side is resting on one of its sides on HP while the corner opposite to this side touches VP. If the lamina makes an angle of 60 deg. with HP and 30 deg. with VP. Draw the projections of the lamina.

Solution:

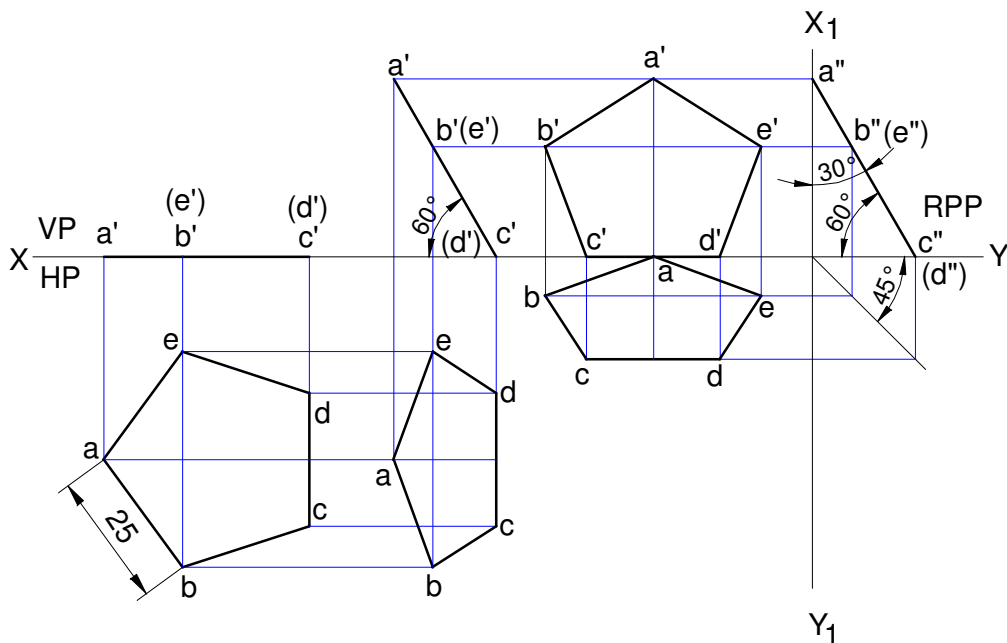

40. (34) A regular hexagonal lamina of 30 mm sides lying in such a way that one of its sides touches both the reference planes. If the lamina makes 60 deg. with HP. Draw the projections of the lamina.

Solution:

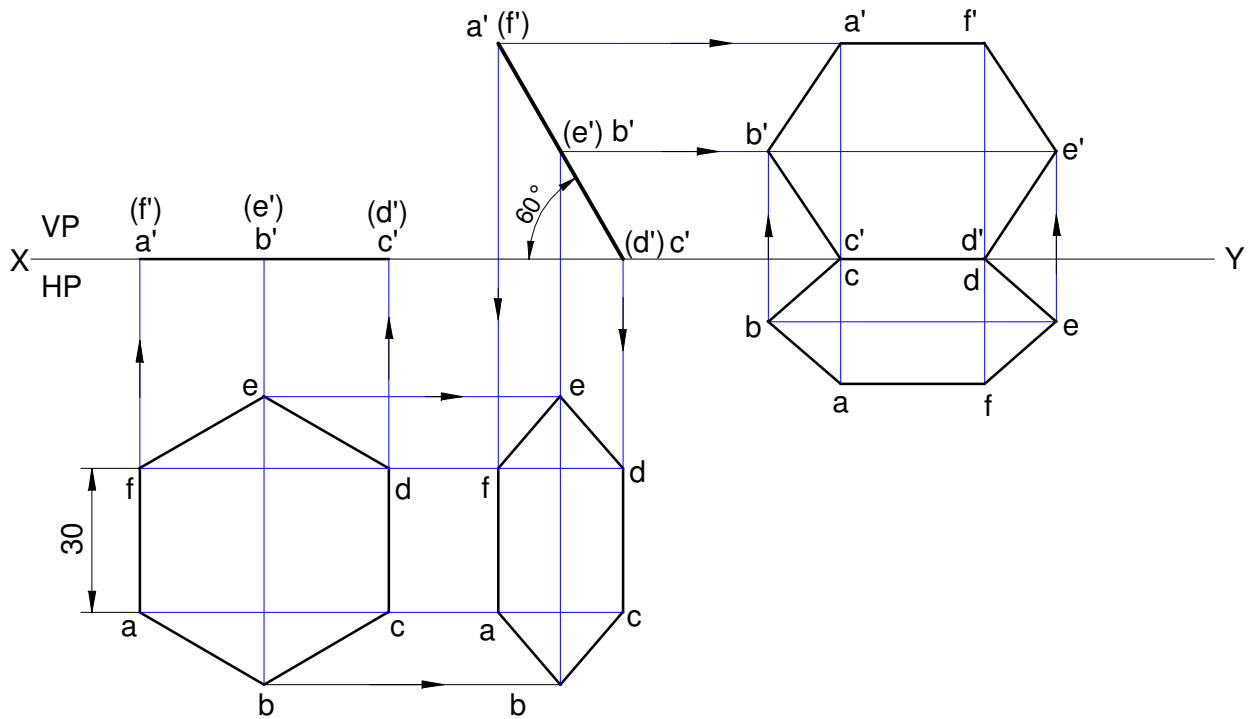

41. (36) A regular hexagonal lamina of sides 25 mm is lying in such a way that one of its sides on HP while the side opposite to the side on which it rests on VP. If the lamina makes 60 deg. to HP. Draw the projections of the lamina.

Solution:

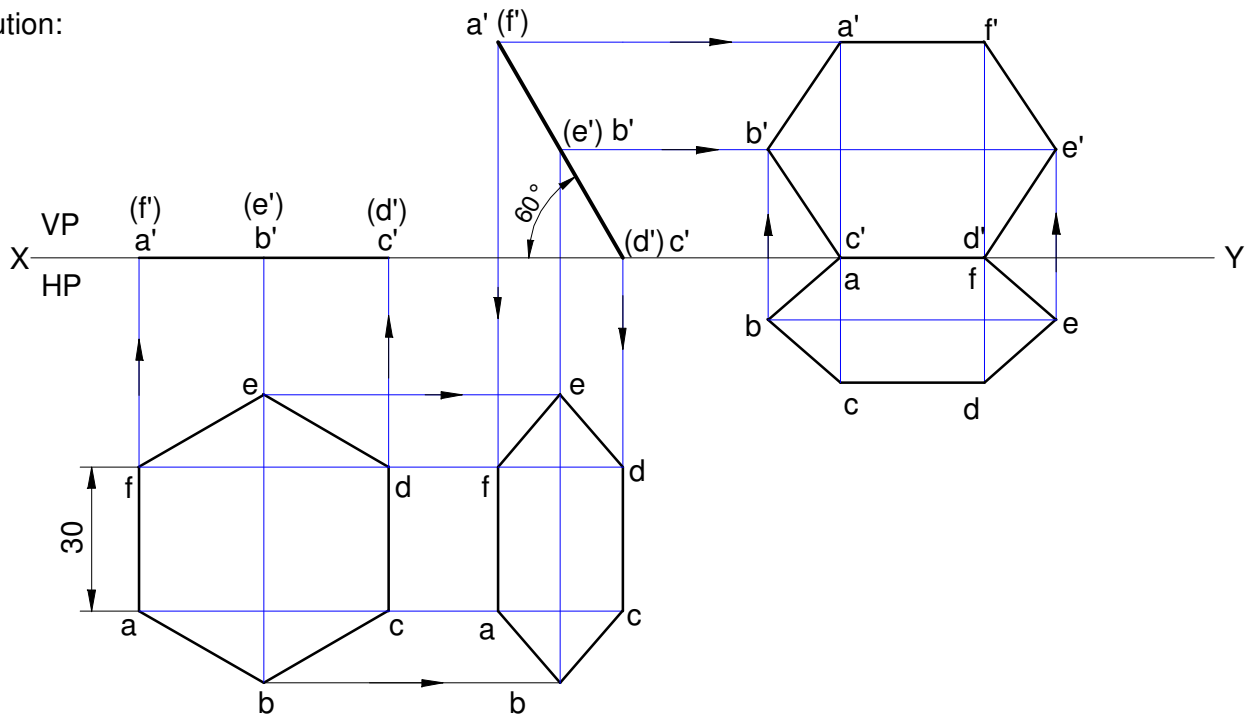

Projections of Planes

41. (37) A regular hexagonal lamina of side 25 mm is lying in such a way that one of its corners on HP while the corner opposite to the corner on which it rests on VP. If the lamina makes 60 deg. to HP. Draw the projections of the lamina.

Solution:

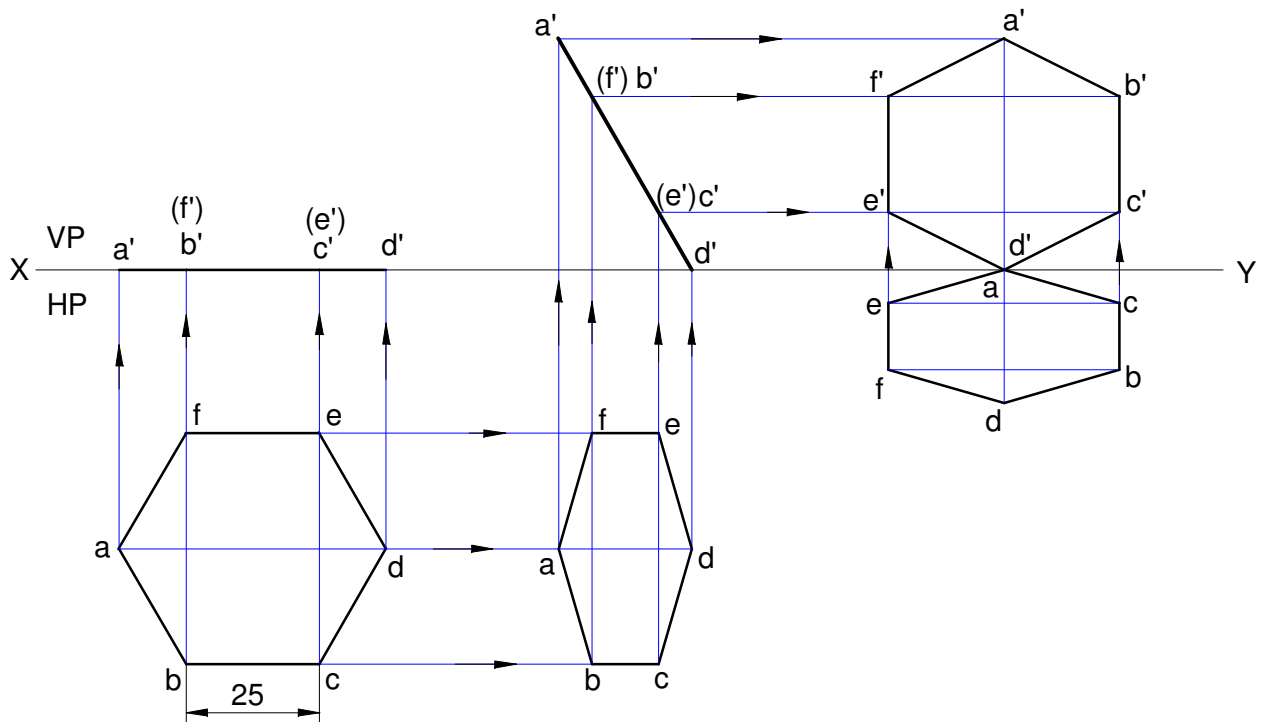

43. (33) Draw the top and front views of a hexagonal lamina of 30 mm sides having two of its edges parallel to both HP and VP and one of its edges 10 mm from each of the planes of projection. The surface of the lamina is inclined at an angle of 60 deg. to the HP.

Solution:

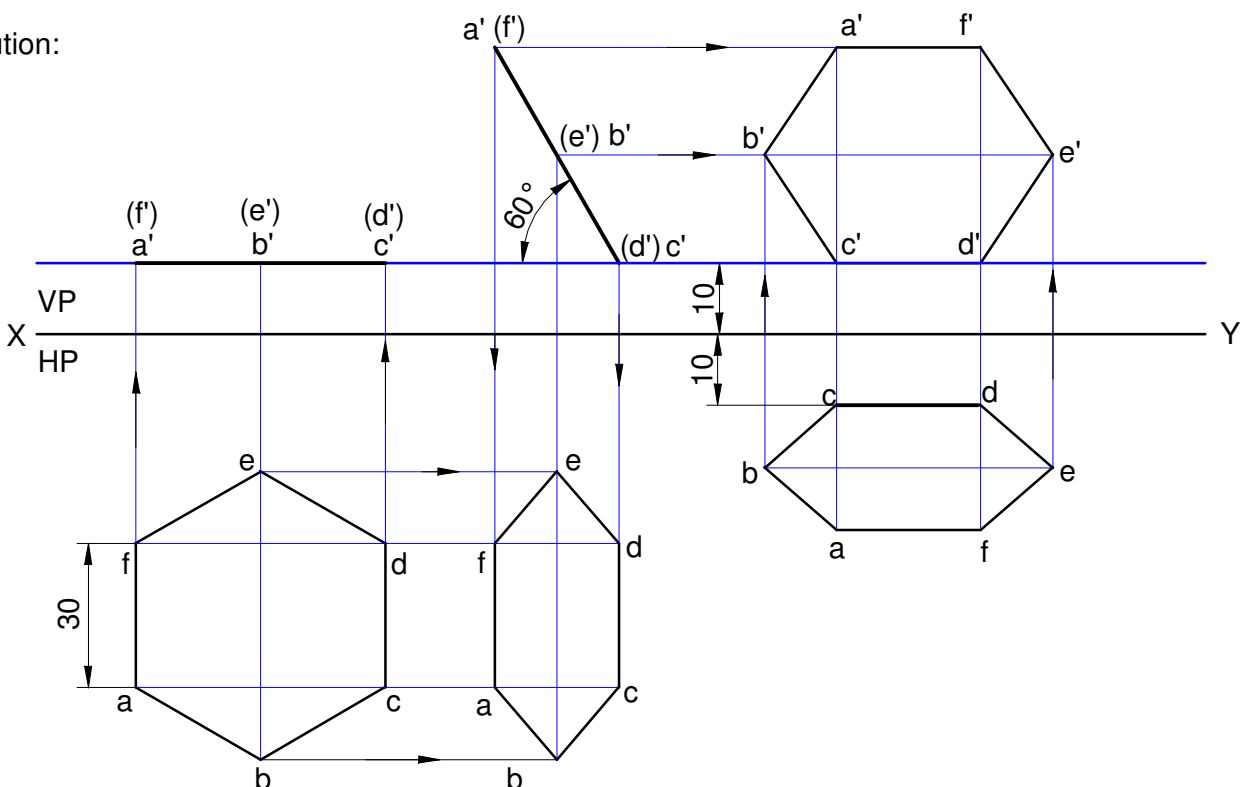

44. (47) A circular lamina of 50 mm diameter is standing with one of its points on the rim on HP and the lamina inclined at 45 deg. to HP. The diameter at right angle to the diameter which is passing through the point on which the lamina rests is parallel to VP. Draw its projections.

Solution:

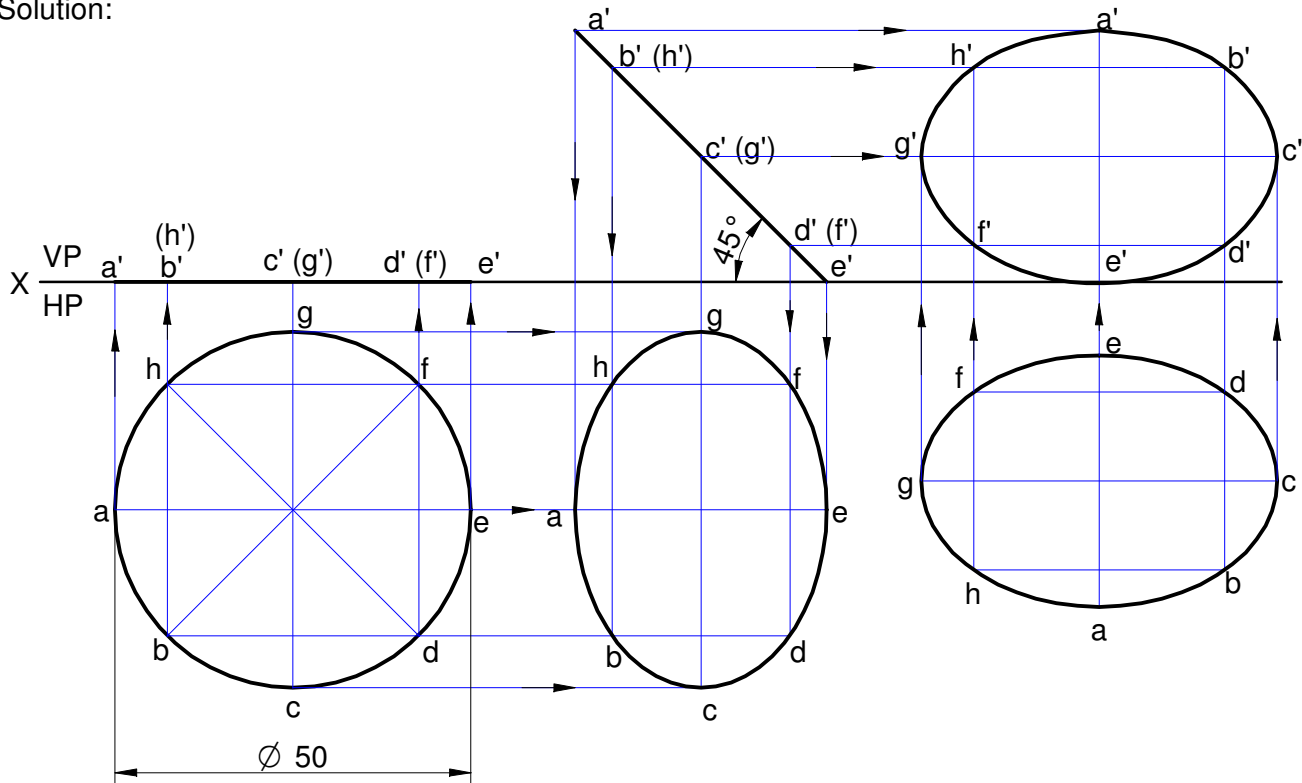

45. (7) An isosceles triangular plate of negligible thickness has base 25 mm long and altitude 35 mm it is placed on HP such that in the front view is seen as an equilateral triangle of 25 mm sides with the side that is parallel to VP is inclined at 45 deg. to HP. Draw its top and front views. Also determine the inclination of the plate with the reference plane.

Solution:

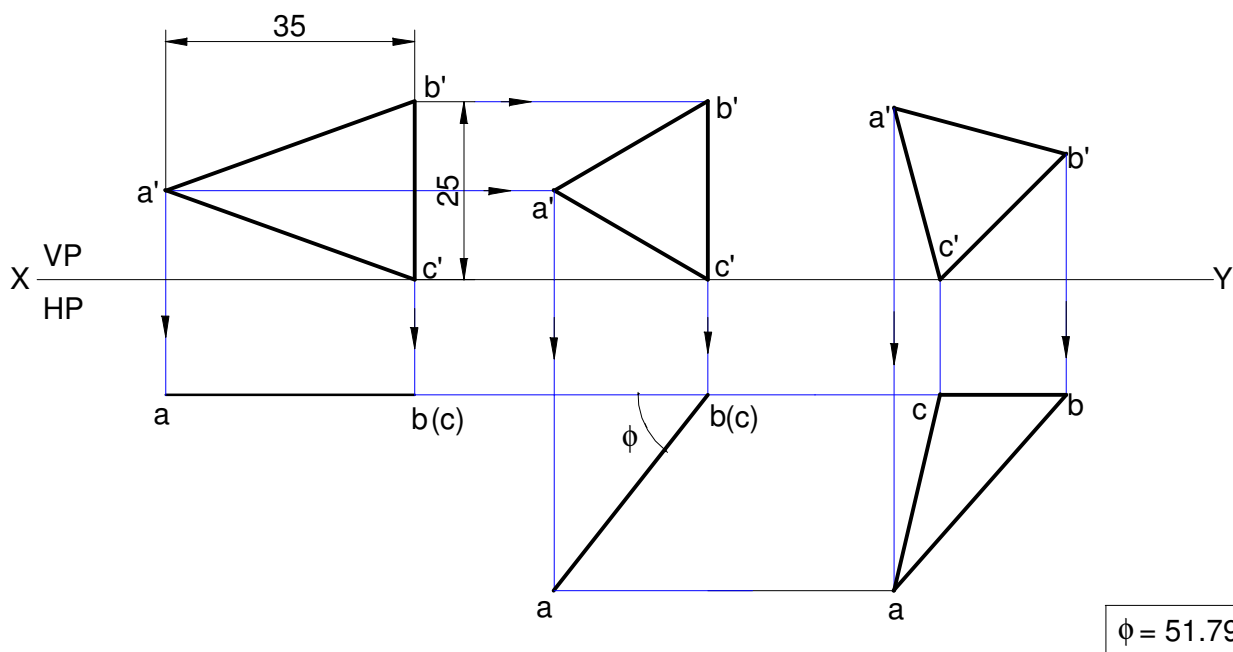

$\phi = 51.79^\circ$

Projections of Planes

46. (15) A rectangular lamina of sides 20 mm X 25 mm has an edge in HP and adjoining edge in VP, is tilted such that the front view appears as a rectangle of 20 mm X 15 mm. The edge which is in VP is 30 mm from the right profile plane.

- a) Draw the top view, front view and the left profile view in this position.
- b) Find its inclinations with the corresponding principal planes.

Solution:

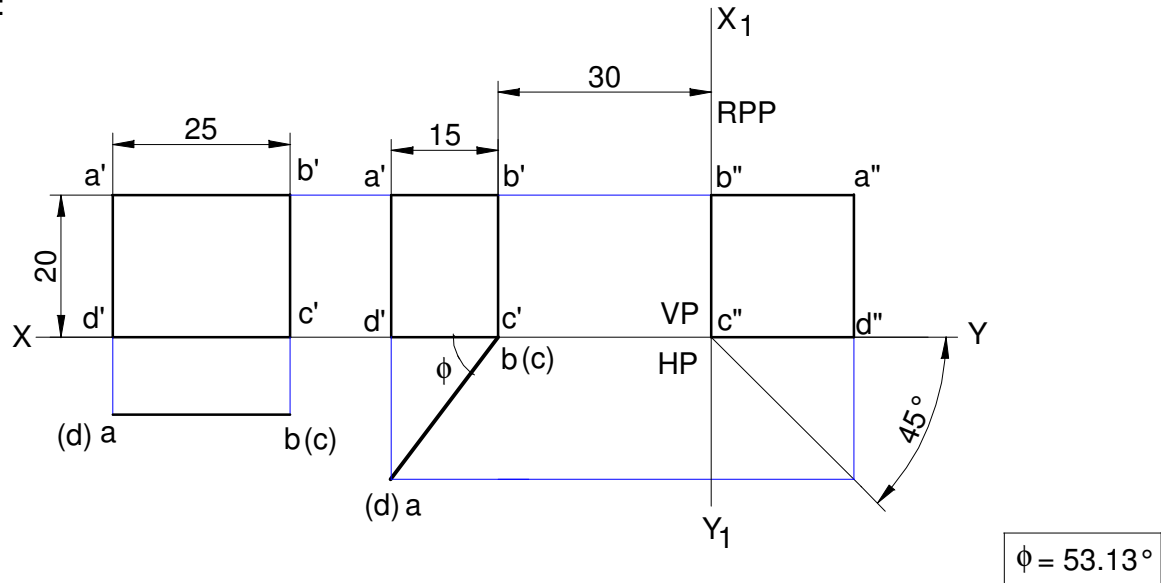

47. (17) A mirror 30 mm X 40 mm is inclined to the wall such that its front view is a square of 30 mm side. The longer side of the mirror appear perpendicular to both HP and VP. Find the inclination of the mirror with the wall.

Solution:

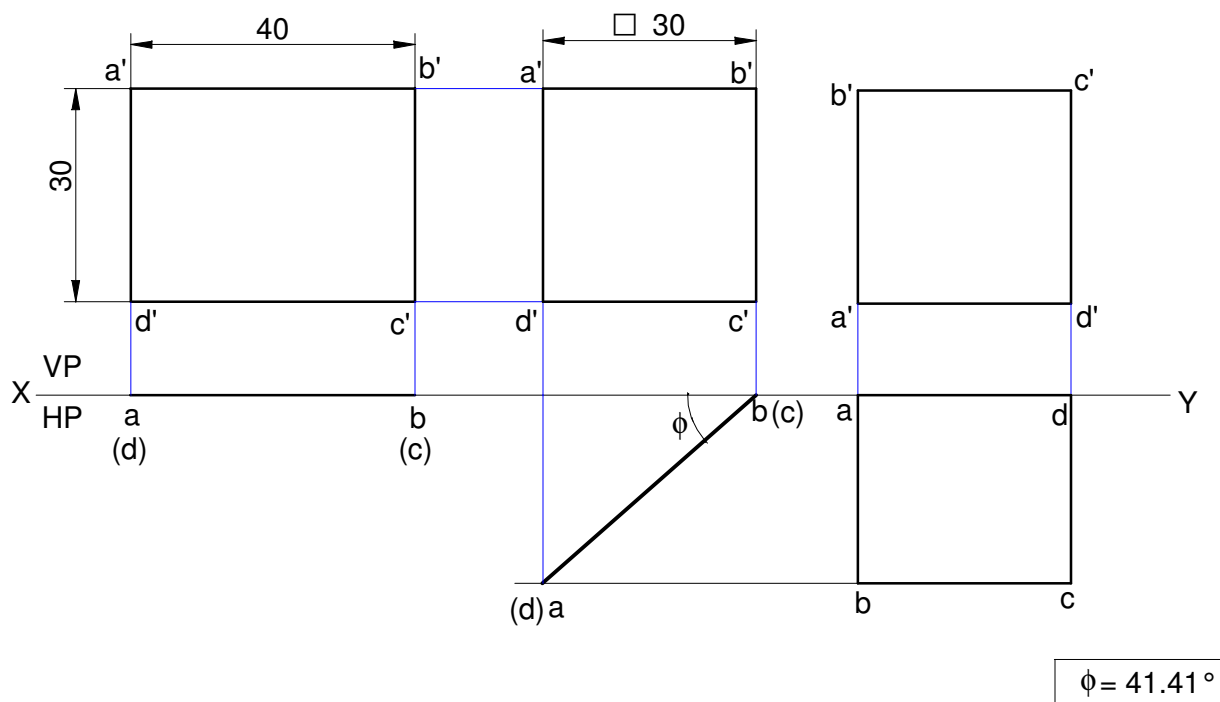

48. (32). A hexagonal lamina of 30 mm sides rests on HP with one of its corners touching VP and the surface inclined at 45 deg. to it. One of its edges inclined to HP at 30 deg. Draw the top and front views of the lamina in its final position.

Solution:

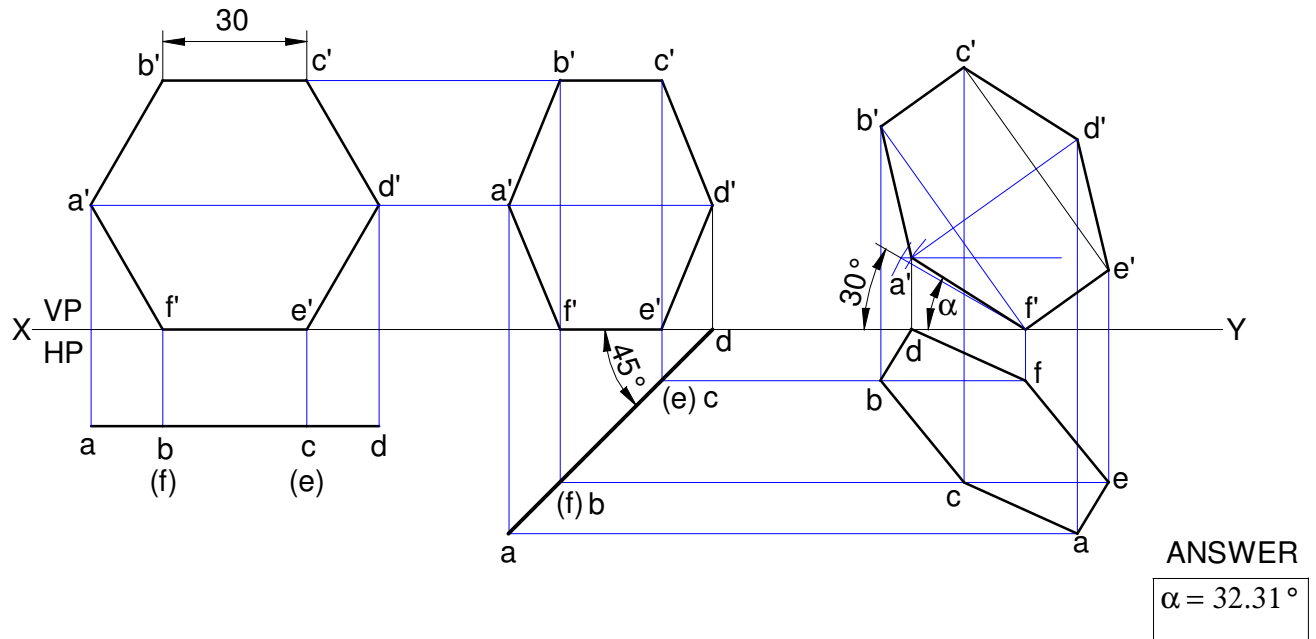

49. (49) A circular lamina inclined to the VP appears in the front view as an ellipse of major axis 30mm & minor axis 15 mm. The major axis is parallel to both HP and VP. One end of the minor axis is in both the HP and VP. Draw the projections of the lamina and determine the inclination of the lamina with the VP.

Solution:

